

Model K-P4
(Machine Code: G116)

Model C-P2b/P2c
(Machine Code: G112/G113)

SERVICE MANUAL

26 November 2004
Subject to change

Trademarks

Microsoft®, Windows®, and MS-DOS® are registered trademarks of Microsoft Corporation in the United States and /or other countries.

PostScript® is a registered trademark of Adobe Systems, Incorporated.

PCL® is a registered trademark of Hewlett-Packard Company.

Ethernet® is a registered trademark of Xerox Corporation.

PowerPC® is a registered trademark of International Business Machines Corporation.

Other product names used herein are for identification purposes only and may be trademarks of their respective companies. We disclaim any and all rights involved with those marks.

IMPORTANT SAFETY NOTICES

PREVENTION OF PHYSICAL INJURY

1. Before disassembling or assembling parts of the printer and peripherals, make sure that the printer power cord is unplugged.
2. The wall outlet should be near the printer and easily accessible.
3. Note that some components of the printer and the paper tray unit are supplied with electrical voltage even if the main power switch is turned off.
4. If any adjustment or operation check has to be made with exterior covers off or open while the main switch is turned on, keep hands away from electrified or mechanically driven components.
5. The inside and the metal parts of the fusing unit become extremely hot while the printer is operating. Be careful to avoid touching those components with your bare hands.

HEALTH SAFETY CONDITIONS

Toner and developer are non-toxic, but if you get either of them in your eyes by accident, it may cause temporary eye discomfort. Try to remove with eye drops or flush with water as first aid. If unsuccessful, get medical attention.

OBSERVANCE OF ELECTRICAL SAFETY STANDARDS

1. The printer and its peripherals must be installed and maintained by a customer service representative who has completed the training course on those models.
2. The NVRAM on the system control board has a lithium battery which can explode if replaced incorrectly. Replace the NVRAM only with an identical one. The manufacturer recommends replacing the entire NVRAM. Do not recharge or burn this battery. Used NVRAM must be handled in accordance with local regulations.

SAFETY AND ECOLOGICAL NOTES FOR DISPOSAL

1. Do not incinerate toner bottles or used toner. Toner dust may ignite suddenly when exposed to an open flame.
2. Dispose of used toner, developer, and organic photoconductors in accordance with local regulations. (These are non-toxic supplies.)
3. Dispose of replaced parts in accordance with local regulations.
4. When keeping used lithium batteries in order to dispose of them later, do not put more than 100 batteries per sealed box. Storing larger numbers or not sealing them apart may lead to chemical reactions and heat build-up.

LASER SAFETY

The Center for Devices and Radiological Health (CDRH) prohibits the repair of laser-based optical units in the field. The optical housing unit can only be repaired in a factory or at a location with the requisite equipment. The laser subsystem is replaceable in the field by a qualified Customer Engineer. The laser chassis is not repairable in the field. Customer engineers are therefore directed to return all chassis and laser subsystems to the factory or service depot when replacement of the optical subsystem is required.

⚠ WARNING
Use of controls, or adjustment, or performance of procedures other than those specified in this manual may result in hazardous radiation exposure.

⚠ WARNING
WARNING: Turn off the main switch before attempting any of the procedures in the Laser Unit section. Laser beams can seriously damage your eyes.

Caution Labels

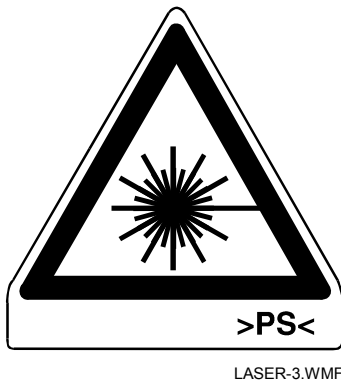

CAUTION VORSICHT >PS<	INVISIBLE LASER RADIATION WHEN OPEN. AVOID EXPOSURE TO BEAM. UNSICHTBARE LASERSTRAHLUNG WENN ABDECKUNG GEÖFFNET. NICHT DEM STRAHL AUSSETZEN.
--	---

G065RLV.WMF

 DANGER	INVISIBLE LASER RADIATION WHEN OPEN. AVOID DIRECT EXPOSURE TO BEAM.
>PS<	

LASER-1.WMF

Lithium Batteries (Memory Back-up)

CAUTION







The danger of explosion exists if a battery of this type is incorrectly replaced. Replace only with the same or an equivalent type recommended by the manufacturer. Discard used batteries in accordance with the manufacturer's instructions.

Warning Concerning Copyright

Many documents are copyrighted. Such documents may not be reproduced by copying or in any other form without the express permission of the copyright holder.

Conventions in this Manual

This manual uses several symbols and some simple abbreviations.

Symbol	What it means
	Refer to section number
	See Core Tech Manual for details
	Screw
	Connector
	E-ring
	C-ring
HP	Home Position
T/S	Transfer/Separation

The following notations are used in text to describe the direction of paper feed: lengthwise and sideways. The annotations "SEF" and "LEF" denote "Short Edge Feed" and "Long Edge Feed". (The arrows indicate the direction of paper feed.)

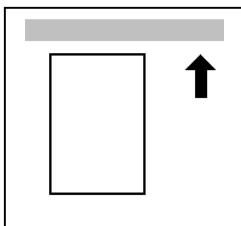

Lengthwise (SEF)

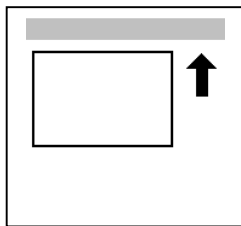

Sideways (LEF)

TABLE OF CONTENTS

1. INSTALLATION	1-1
2. PREVENTIVE MAINTENANCE SCHEDULE	2-1
2.1 USER MAINTENANCE	2-1
2.1.1 USER MAINTENANCE [G112/G113]	2-1
2.1.2 USER MAINTENANCE [G116]	2-1
2.2 SERVICE MAINTENANCE	2-2
2.2.1 MAIN UNIT [G112/G113/G116]	2-2
2.2.2 PAPER TRAY UNIT [G112/G113/G116]	2-2
3. REPLACEMENTS AND ADJUSTMENTS	3-1
3.1 GENERAL	3-1
3.1.1 PRECAUTIONS ON DISASSEMBLY [G112/G113/G116]	3-1
3.1.2 RELEASING PLASTIC LATCHES [G112/G113/G116]	3-1
3.1.3 AFTER SERVICING THE MACHINE [G112/G113/G116]	3-1
3.2 SPECIAL TOOLS	3-1
3.3 COVERS	3-1
3.3.1 FRONT COVER [G112/G113/G116]	3-1
3.3.2 UPPER COVER [G112/G113]	3-1
3.3.3 UPPER COVER [G116]	3-1
3.3.4 BY-PASS TRAY UNIT [G112/G113/G116]	3-1
3.3.5 EXTERIOR COVERS [G112/G113]	3-1
3.3.6 EXTERIOR COVERS [G116]	3-1
3.4 LASER UNIT	3-2
3.4.1 CAUTION DECAL LOCATIONS [G112/G113/G116]	3-2
3.4.2 POLYGON MIRROR MOTOR [G112/G113/G116]	3-3
3.4.3 LASER SYNCHRONIZATION DETECTOR [G112/G113/G116]	3-3
3.4.4 LASER UNIT [G112/G113]	3-3
3.4.5 LASER UNIT [G116]	3-3
When reinstalling the laser unit	3-3
3.4.6 LASER DIODE UNIT [G112/G113/G116]	3-3
3.4.7 LASER BEAM PITCH ADJUSTMENT [G112/G113/G116]	3-3
3.5 TRANSFER ROLLER	3-3
3.6 TONER END SENSOR	3-3
3.7 FUSING	3-4
3.7.1 FUSING UNIT [G112/G113/G116]	3-4
3.7.2 HOT ROLLER AND FUSING LAMP [G112/G113/G116]	3-4
3.7.3 PRESSURE ROLLER [G112/G113/G116]	3-4
3.7.4 THERMISTOR AND THERMOSTAT [G112/G113/G116]	3-4
3.7.5 HOT ROLLER STRIPPERS [G112/G113]	3-4
3.7.6 HOT ROLLER STRIPPERS [G116]	3-4
3.8 PAPER FEED	3-4
3.8.1 PAPER FEED ROLLER [G112/G113/G116]	3-4
3.8.2 FRICTION PAD [G112/G113/G116]	3-4
3.9 BY-PASS TRAY [G112/G113/G116]	3-5

3.9.1 BY-PASS TRAY UNIT AND BY-PASS FEED ROLLER	3-5
LEFT COVER [G094/G095] *3.3.5, [G091] *3.3.6	3-5
FRONT COVER [G094/G095] *3.3.5, [G091] *3.3.6.....	3-5
3.10 PRINTER CONTROLLER BOARD [G112/G113/G116]	3-6
3.11 ENGINE BOARD [G112/G113/G116].....	3-6
3.12 MAIN MOTOR [G112/G113/G116]	3-6
3.13 SOLENOIDS AND CLUTCHES [G112/G113/G116].....	3-6
3.14 POWER SUPPLY BOARD AND HIGH VOLTAGE SUPPLY BOARD [G112/G113/G116]	3-6
3.15 COOLING FAN [G112/G113/G116].....	3-6
3.16 IMAGE ADJUSTMENT	3-6
3.16.1 REGISTRATION ADJUSTMENT [G112/G113/G116].....	3-6
3.16.2 PARALLELOGRAM IMAGE ADJUSTMENT [G112/G113/G116] ...	3-6
4. TROUBLESHOOTING	4-1
4.1 SERVICE CALL CONDITIONS	4-1
4.1.1 SUMMARY	4-1
4.1.2 SC CODE DESCRIPTIONS	4-2
4.2 CONTROLLER ERROR	4-4
4.3 ELECTRICAL COMPONENT DEFECTS	4-6
4.3.1 SENSORS	4-6
4.3.2 SWITCHES.....	4-6
4.4 BLOWN FUSE CONDITIONS	4-6
4.5 LEDS	4-6
5. SERVICE TABLES.....	5-1
5.1 SERVICE PROGRAM MODE [G112/G113/G116]	5-1
5.1.1 ENABLING AND DISABLING SERVICE PROGRAM MODE	5-1
Entering the Service Mode.....	5-1
Inputting a Value or Setting for a Service Program.....	5-1
Exiting Service Mode	5-1
5.2 PRINTER CONTROLLER SERVICE MODE [G112/G113/G116].....	5-2
5.2.1 SERVICE MODE MENU (“1. SERVICE MENU”).....	5-2
5.2.2 BIT SWITCH PROGRAMMING [G112/G113/G116].....	5-2
5.3 PRINTER ENGINE SERVICE MODE [G112/G113/G116]	5-3
5.3.1 SERVICE MODE TABLE.....	5-3
SP1-xxx: Feed	5-3
SP2-xxx: Drum.....	5-4
SP3-xxx: Process.....	5-5
SP5-xxx: Mode	5-6
SP7-xxx: Data Log.....	5-17
SP8-xxx: Counters	5-21
SP9-xxx: Counters	5-25
5.4 UPDATING THE FIRMWARE	5-26
5.4.1 TYPE OF FIRMWARE.....	5-26
5.4.2 PRECAUTIONS.....	5-26
Handling SD Cards	5-26
Upload or Download	5-26
Network Connection.....	5-26

5.4.3	MACHINE FIRMWARE [G112/G113/G116]	5-27
5.4.4	ERROR RECOVERY [G112/G113/G116]	5-27
5.5	NVRAM DATA UPLOAD/DOWNLOAD	5-28
	Uploading NVRAM Data	5-28
	Downloading NVRAM Data	5-29
5.6	REMOTE FIRMWARE UPDATE (RFU) [G112/G113/G116]	5-30
5.7	LOOP-BACK TEST [G112/G113/G116]	5-30
5.8	POWER-ON SELF TESTS [G112/G113/G116]	5-30
5.9	DIP SWITCHES [G112/G113/G116]	5-30
5.10	SD CARD APPLI MOVE	5-30
5.10.1	OVERVIEW	5-30
5.10.2	MOVE EXEC	5-31
5.10.3	UNDO EXEC	5-32

6. DETAILED DESCRIPTIONS 6-1

6.1	OVERVIEW	6-1
6.1.1	MECHANICAL COMPONENT LAYOUT [G112/G113/G116]	6-1
6.1.2	PAPER PATH [G112/G113]	6-1
6.1.3	PAPER PATH [G116]	6-1
6.2	BOARD STRUCTURE	6-1
6.2.1	BLOCK DIAGRAM [G112/G113]	6-1
6.2.2	BLOCK DIAGRAM [G116]	6-1
6.2.3	DESCRIPTIONS [G112/G113/G116]	6-1
6.2.4	CONTROLLER [G112/G113]	6-1
6.2.5	CONTROLLER [G116]	6-1
6.3	PRINTING PROCESS	6-2
6.3.1	OVERVIEW [G112/G113/G116]	6-2
6.3.2	LASER EXPOSURE [G112/G113/G116]	6-2
	Automatic Process Control (APC) [G112/G113/G116]	6-2
	LD Safety Mechanisms [G112/G113/G116]	6-2
6.3.3	CARTRIDGE OVERVIEW [G112/G113/G116]	6-2
6.3.4	DRUM CHARGE [G112/G113/G116]	6-2
6.3.5	DEVELOPMENT [G112/G113/G116]	6-2
	Toner Density Control [G112/G113/G116]	6-2
	Toner End Detection [G112/G113/G116]	6-2
6.3.6	IMAGE TRANSFER AND PAPER SEPARATION	6-2
	Overview [G112/G113/G116]	6-2
	Transfer Roller Cleaning [G112/G113/G116]	6-2
6.3.7	CLEANING [G112/G113/G116]	6-2
6.3.8	QUENCHING [G112/G113/G116]	6-2
6.4	PAPER FEED	6-3
6.4.1	OVERVIEW [G112/G113/G116]	6-3
6.4.2	PAPER TRAY [G112/G113/G116]	6-3
	Tray Extension [G112/G113/G116]	6-3
	Paper Lift [G112/G113/G116]	6-3
	Paper Feed and Registration [G112/G113/G116]	6-3
	Paper Size Detection [G112/G113/G116]	6-3
	Paper Size Detection [G112/G113]	6-3
	Paper Size Detection [G116]	6-3

Paper End Detection [G112/G113/G116].....	6-3
Remaining Paper Detection [G112/G113/G116].....	6-3
6.4.3 BY-PASS TRAY [G112/G113/G116]	6-4
6.5 IMAGE FUSING AND PAPER EXIT	6-5
6.5.1 OVERVIEW [G112/G113/G116].....	6-5
6.5.2 FUSING DRIVE [G112/G113/G116].....	6-5
6.5.3 FUSING ENTRANCE AND GUIDE SHAFT [G112/G113/G116].....	6-5
6.5.4 PRESSURE ROLLER [G112/G113/G116]	6-5
6.5.5 NEW FUSING UNIT DETECTION [G112/G113/G116].....	6-5
6.5.6 FUSING TEMPERATURE CONTROL [G112/G113/G116]	6-5
Overheat Protection [G112/G113/G116].....	6-5
6.5.7 PAPER EXIT [G112/G113/G116]	6-5
6.5.8 ENERGY SAVER MODE [G112/G113/G116]	6-5
6.6 CONTROLLER FUNCTIONS	6-5
6.6.1 METER CHARGE MODE [G112/G113/G116].....	6-5

PERIPHERALS

PAPER TRAY UNIT (G399)/ENVELOPE FEEDER (G807)

1. REPLACEMENT AND ADJUSTMENT.....	G399-1
1.1 PAPER FEED UNIT	G399-1
1.2 PAPER FEED ROLLER	G399-1
1.3 FRICTION PAD	G399-1
1.4 PAPER FEED CLUTCH	G399-1
1.5 PAPER TRAY BOARD	G399-1
1.6 PAPER SIZE SWITCH	G399-1
2. DETAILED DESCRIPTIONS	G399-2
2.1 OVERALL MACHINE INFORMATION	G399-2
2.1.1 MECHANICAL COMPONENT LAYOUT.....	G399-2
2.1.2 ELECTRICAL COMPONENT LAYOUT	G399-2
2.2 DETAILED DESCRIPTIONS	G399-2
2.2.1 PAPER FEED AND SEPARATION	G399-2
2.2.2 PAPER LIFT	G399-2
2.2.3 PAPER END DETECTION	G399-2
2.2.4 REMAINING PAPER DETECTION.....	G399-2
2.2.5 PAPER SIZE DETECTION.....	G399-2
2.2.6 PAPER PRESSURE SWITCH.....	G399-3
Do this procedure to use the paper pressure switch:.....	G399-3
2.3 PROTECTION FUSE	G399-4
3. ENVELOPE FEEDER.....	G399-5
3.1 OVERALL MACHINE INFORMATION	G399-5
3.1.1 MECHANICAL COMPONENT LAYOUT.....	G399-5

DUPLEX UNIT (G806)

1. REPLACEMENT AND ADJUSTMENT.....	G806-1
1.1 EXTERIOR COVERS	G806-1
1.2 DUPLEX BOARD AND SENSORS	G806-1
2. DETAILED DESCRIPTIONS	G806-2
2.1 OVERALL MACHINE INFORMATION	G806-2
2.1.1 MECHANICAL COMPONENT LAYOUT.....	G806-2
2.1.2 DRIVE LAYOUT	G806-2
2.1.3 ELECTRICAL COMPONENT LAYOUT	G806-2
2.2 DETAILED DESCRIPTIONS	G806-2
2.2.1 BASIC OPERATION.....	G806-2
2.2.2 FEED IN AND EXIT MECHANISM	G806-2

SPECIFICATIONS

SPECIFICATIONS (G112/G113)	SPEC-1
1. GENERAL SPECIFICATIONS.....	SPEC-1
2. PHYSICAL SPECIFICATIONS.....	SPEC-2
3. CONTROLLER.....	SPEC-3
4. SUPPORTED PAPER SIZES.....	SPEC-4
5. OPERATION PANEL LED SPECIFICATIONS.....	SPEC-5
6. EXTERNAL OPTIONS.....	SPEC-5
7. SOFTWARE ACCESSORIES.....	SPEC-6
7.1 PRINTER DRIVERS.....	SPEC-6
7.2 CD-ROM CONTENTS.....	SPEC-7
7.2.1 NORTH AMERICAN VERSION.....	SPEC-7
7.2.2 EUROPEAN VERSION.....	SPEC-8
8. MACHINE CONFIGURATION.....	SPEC-9
8.1 SYSTEM COMPONENTS.....	SPEC-9
8.2 INTERNAL OPTIONS.....	SPEC-10

SPECIFICATIONS (G116)	SPEC-1
1. GENERAL SPECIFICATIONS.....	SPEC-1
2. PHYSICAL SPECIFICATIONS.....	SPEC-2
3. CONTROLLER.....	SPEC-3
4. SUPPORTED PAPER SIZES.....	SPEC-4
5. OPERATION PANEL LED SPECIFICATIONS.....	SPEC-5
6. EXTERNAL OPTIONS.....	SPEC-6
7. SOFTWARE ACCESSORIES.....	SPEC-7
7.1 PRINTER DRIVERS.....	SPEC-7
7.2 OPERATING SYSTEMS/NETWORKS.....	SPEC-7
7.3 CD-ROM CONTENTS.....	SPEC-8
7.3.1 NORTH AMERICAN VERSION.....	SPEC-8
7.3.2 EUROPEAN VERSION.....	SPEC-9
8. MACHINE CONFIGURATION.....	SPEC-10
8.1 SYSTEM COMPONENTS.....	SPEC-10
8.2 INTERNAL OPTIONS.....	SPEC-11

1. INSTALLATION

Refer to the G091/G094/G095 Service Manual for Installation details.

2. SPREVENTIVE MAINTENANCE SCHEDULE

2.1 USER MAINTENANCE

The descriptions in this section are for the G112/G113/G116 machines.

The customer can do all PM items with the Maintenance Kit.

Meter-charge mode must be set to “disabled” (Engine SP 5930).

Cross-reference: ● Section 5.3 Engine service mode

The operation panel shows “Replace Maintenance Kit” when the PM counter gets to 90K. After the user replaces the fusing unit in the maintenance kit, the machine automatically resets the PM counter.

2.1.1 USER MAINTENANCE [G112/G113]

Refer to the G091/G094/G095 Service Manual for details

2.1.2 USER MAINTENANCE [G116]

Refer to the G091/G094/G095 Service Manual for details

2.2 SERVICE MAINTENANCE

- NOTE:** 1) Set the meter-charge mode to “on” in printer engine service mode to disable the user’s PM warning.
- 2) Make sure to reset the PM counters with engine SP 7804 after you complete PM.
- SP 7804 1: Transfer roller
 - SP 7804 2: Paper feed roller
 - SP 7804 3: Fusing unit.
 - SP 7804 255: Paper

2.2.1 MAIN UNIT [G112/G113/G116]

Refer to the G091/G094/G095 Service Manual for details

2.2.2 PAPER TRAY UNIT [G112/G113/G116]

Refer to the G091/G094/G095 Service Manual for details

3. REPLACEMENTS AND ADJUSTMENTS

3.1 GENERAL

3.1.1 PRECAUTIONS ON DISASSEMBLY [G112/G113/G116]

Refer to the G091/G094/G095 Service Manual

3.1.2 RELEASING PLASTIC LATCHES [G112/G113/G116]

Refer to the G091/G094/G095 Service Manual

3.1.3 AFTER SERVICING THE MACHINE [G112/G113/G116]

Refer to the G091/G094/G095 Service Manual

Replacement
Adjustment

3.2 SPECIAL TOOLS

Refer to the G091/G094/G095 Service Manual

3.3 COVERS

3.3.1 FRONT COVER [G112/G113/G116]

Refer to the G091/G094/G095 Service Manual

3.3.2 UPPER COVER [G112/G113]

Refer to the G091/G094/G095 Service Manual

3.3.3 UPPER COVER [G116]

Refer to the G091/G094/G095 Service Manual

3.3.4 BY-PASS TRAY UNIT [G112/G113/G116]

Refer to the G091/G094/G095 Service Manual

3.3.5 EXTERIOR COVERS [G112/G113]

Refer to the G091/G094/G095 Service Manual

3.3.6 EXTERIOR COVERS [G116]

Refer to the G091/G094/G095 Service Manual

3.4 LASER UNIT

<p>⚠ WARNING</p> <p>Turn off the main power switch and unplug the machine before attempting any of the procedures in this section. Laser beams can seriously damage your eyes.</p>

3.4.1 CAUTION DECAL LOCATIONS [G112/G113/G116]

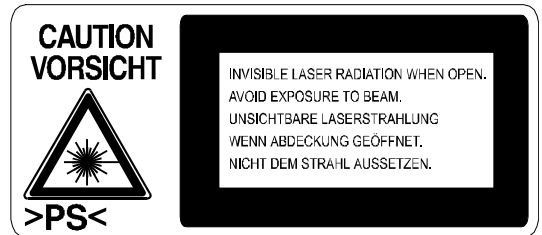

G116R516.WMF

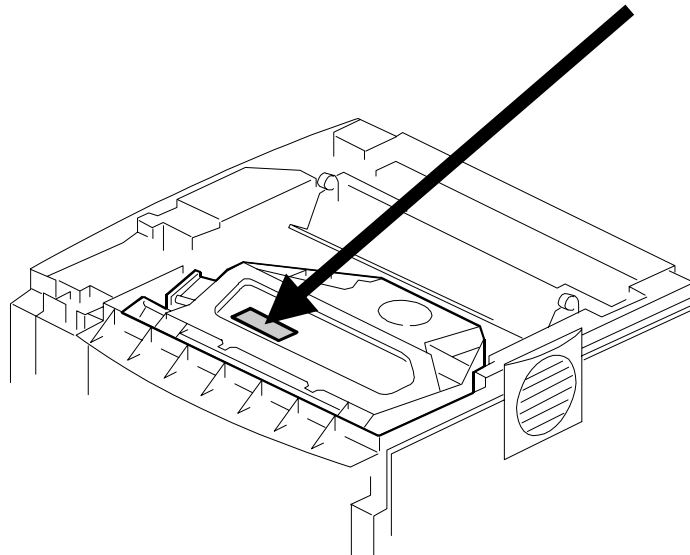

G116R517.WMF

3.4.2 POLYGON MIRROR MOTOR [G112/G113/G116]

Refer to the G091/G094/G095 Service Manual

3.4.3 LASER SYNCHRONIZATION DETECTOR [G112/G113/G116]

Refer to the G091/G094/G095 Service Manual

3.4.4 LASER UNIT [G112/G113]

Refer to the G091/G094/G095 Service Manual

3.4.5 LASER UNIT [G116]

Refer to the G091/G094/G095 Service Manual

When reinstalling the laser unit

Refer to the G091/G094/G095 Service Manual

3.4.6 LASER DIODE UNIT [G112/G113/G116]

Refer to the G091/G094/G095 Service Manual

3.4.7 LASER BEAM PITCH ADJUSTMENT [G112/G113/G116]

Refer to the G091/G094/G095 Service Manual

3.5 TRANSFER ROLLER

Refer to the G091/G094/G095 Service Manual

3.6 TONER END SENSOR

Refer to the G091/G094/G095 Service Manual

3.7 FUSING

3.7.1 FUSING UNIT [G112/G113/G116]

Refer to the G091/G094/G095 Service Manual

3.7.2 HOT ROLLER AND FUSING LAMP [G112/G113/G116]

Refer to the G091/G094/G095 Service Manual

3.7.3 PRESSURE ROLLER [G112/G113/G116]

Refer to the G091/G094/G095 Service Manual

3.7.4 THERMISTOR AND THERMOSTAT [G112/G113/G116]

Refer to the G091/G094/G095 Service Manual

3.7.5 HOT ROLLER STRIPPERS [G112/G113]

Refer to the G091/G094/G095 Service Manual

3.7.6 HOT ROLLER STRIPPERS [G116]

Refer to the G091/G094/G095 Service Manual

3.8 PAPER FEED

3.8.1 PAPER FEED ROLLER [G112/G113/G116]

Refer to the G091/G094/G095 Service Manual

3.8.2 FRICTION PAD [G112/G113/G116]

Refer to the G091/G094/G095 Service Manual

3.9 BY-PASS TRAY [G112/G113/G116]

3.9.1 BY-PASS TRAY UNIT AND BY-PASS FEED ROLLER

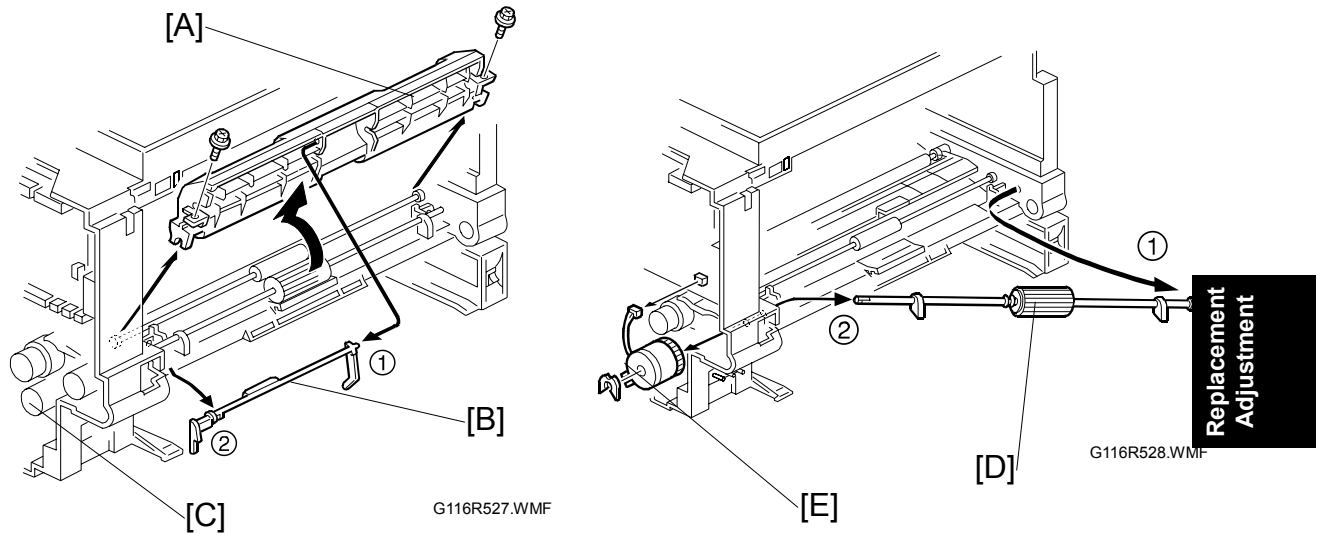

Left Cover [G094/G095] ➔ 3.3.5, [G091] ➔ 3.3.6

Front Cover [G094/G095] ➔ 3.3.5, [G091] ➔ 3.3.6

[A]: Paper guide (2 x 2)

[B]: Actuator

[C]: By-pass feed clutch (1 connector harness, 1 clamp)

[D]: By-pass feed roller

[E] Gear (1 hook)

NOTE: When you reinstall the paper guide

1. Set the paper guide on the bushing.
2. Install the right part of the actuator on the paper guide.
3. Install the left part of the actuator in the machine.
4. Install the paper guide.
5. Check that the actuator moves smoothly and swings freely.

3.10 PRINTER CONTROLLER BOARD [G112/G113/G116]

Refer to the G091/G094/G095 Service Manual



3.11 ENGINE BOARD [G112/G113/G116]

Refer to the G091/G094/G095 Service Manual

3.12 MAIN MOTOR [G112/G113/G116]

Refer to the G091/G094/G095 Service Manual

3.13 SOLENOIDS AND CLUTCHES [G112/G113/G116]

Refer to the G091/G094/G095 Service Manual

3.14 POWER SUPPLY BOARD AND HIGH VOLTAGE SUPPLY BOARD [G112/G113/G116]

Refer to the G091/G094/G095 Service Manual

3.15 COOLING FAN [G112/G113/G116]

Refer to the G091/G094/G095 Service Manual

3.16 IMAGE ADJUSTMENT

3.16.1 REGISTRATION ADJUSTMENT [G112/G113/G116]

Refer to the G091/G094/G095 Service Manual

3.16.2 PARALLELOGRAM IMAGE ADJUSTMENT [G112/G113/G116]

Refer to the G091/G094/G095 Service Manual

4. TROUBLESHOOTING

4.1 SERVICE CALL CONDITIONS

The SC codes in this section are for the G112/G113/G116 machines. SC codes that are not the same for all machines are shown in the left side margin.

4.1.1 SUMMARY

There are 2 levels of service call conditions.

Level	Definition	Reset Procedure
A	Only a service representative can reset this SC. This will prevent damage to the machine. At this time you cannot use the machine.	<i>Enter engine SP 5810 and press “#”. Then press “#” again when ‘execute’ shows. Then press ‘Escape’. Then turn the main power off/on.</i>
B	You can reset the SC by turning the operation switch off and on. Do this if the SC was caused by a sensor error.	Set the main power off and on.

- NOTE:** 1) Disconnect the connectors first if the problem is with electrical circuit boards. Then reconnect the connectors before you replace the PCBs.
2) First examine the mechanical load if the problem is with a motor lock. Then replace motors or sensors.

4.1.2 SC CODE DESCRIPTIONS

Code No.	Symptom	Possible Cause	
302	B	Charge roller current leak A charge roller current leak signal is detected.	<ul style="list-style-type: none"> • Cartridge (charge roller) defective • High voltage supply board defective • Defective cartridge connection
320	B	Polygon motor error The polygon motor does not reach its operating speed within 10 seconds after the polygon motor on signal, or the lock signal is not detected for more than a certain time during operation.	<ul style="list-style-type: none"> • Polygon motor • Polygon motor cable
322	B	1st laser synchronization error The laser synchronization detector cannot detect the laser synchronization signal for more than 5 consecutive 100 ms intervals.	<ul style="list-style-type: none"> • Laser synchronization detector board out of position • Laser synchronization detector board or cable defective • Laser synchronization mirror out of position • LD unit defective • Engine board defective
323	B	LD drive current exceeded The LD driver detects this error for more than 500 ms.	<ul style="list-style-type: none"> • LD unit defective
326	B	2nd laser synchronization error The 1 st LD1 is already on, but the laser synchronization detector cannot detect the laser synchronization signal from the 2 nd LD for more than 5 consecutive 100 ms intervals.	<ul style="list-style-type: none"> • Laser synchronization detector board out of position • LD unit defective • Engine board defective
391	B	Development bias leak A development bias leak signal is detected.	<ul style="list-style-type: none"> • High voltage supply board defective • Defective cartridge connection
500	B	Main motor lock A main motor lock signal is not detected for more than 700 ms after the main motor starts to rotate, or the lock signal is not detected for more than a certain time during rotation after the last signal.	<ul style="list-style-type: none"> • Main motor defective • Too much load on the drive mechanism
541	A	Unstable fusing temperature During warm-up, the fusing temperature rises by less than 20 °C during 11 seconds. The fusing temperature detected by the thermistor was 0 °C 5 seconds after the fusing relay was turned on.	<ul style="list-style-type: none"> • Thermistor defective • Fusing lamp open • Fusing thermostat open • Power supply board defective • Defective connection of the fusing unit
542	A	Fusing temperature warm-up error The fusing temperature does not reach more than 80 °C 17.5 seconds after the main switch is turned on.	<ul style="list-style-type: none"> • Thermistor defective • Fusing lamp open • Fusing thermostat open • Power supply board Defective • Defective connection of the fusing unit

Code No.		Symptom	Possible Cause
543	A	Fusing overheat error	<ul style="list-style-type: none"> • Fusing thermistor defective • Power supply board defective
		A fusing temperature of over 245 °C is detected for 1 second by the fusing thermistor.	
		A fusing temperature of over 235 °C is detected for 1 second after the fusing lamp has been turned off.	
		The dual monitoring circuitry of the BICU detects extremely high temperature and tripped the relay circuit off.	
545	A	Fusing lamp stays on	<ul style="list-style-type: none"> • Fusing thermistor defective • Power supply board defective • Defective connection of the fusing unit
		The fusing lamp stays on more than 12 seconds after the main motor has been turned off.	
546	A	Unstable fusing temperature	<ul style="list-style-type: none"> • Fusing thermistor defective • Power supply board defective • Defective connection of the fusing unit
		During standby, within 500 ms, the fusing temperature goes below 60 °C twice or over 60 °C three times.	
		Within 1 minute, a 60 °C increase or decrease in fusing temperature is detected during five different one-second intervals.	
547	B	Zero cross signal malfunction	<ul style="list-style-type: none"> • Power supply board defective • Defective mains power supply condition
		Zero cross signals are not detected within 5 seconds.	
590 G112/ G113 Only	B	Fusing fan motor error	<ul style="list-style-type: none"> • Poor connection of the exhaust fan motor • Too much load on the motor drive
		The CPU detects an exhaust fan lock signal for more than 3.5 seconds.	
		The engine board cannot communicate with the duplex unit.	
650	B	Communication error - GAVD	<ul style="list-style-type: none"> • Engine board defective
		<ul style="list-style-type: none"> • The engine board detects an unknown device on the IC I/F bus (internal bus on the engine control board). • The engine board detects an IC I/F bus error. 	
651	B	Communication error - FCI	<ul style="list-style-type: none"> • Engine board defective
		<ul style="list-style-type: none"> • The engine board detects an unknown device on the IC I/F bus (internal bus on the engine control board). • The engine board detects an IC I/F bus error. 	
		Tray shift did not finish within a certain time after the shift motor turned on.	
		The IPU does not respond with the settings required to start memory image processing.	

4.2 CONTROLLER ERROR

The following table describes the controller error codes. These codes are displayed at power-on, or after the power-on self-test, if an error occurs.

Code	Description	Required Action
640	Engine to controller communication error.	<ul style="list-style-type: none"> Examine the connection between the controller and the engine board. Replace the engine board if the error is frequent. Replace the controller if the error is frequent.
641	Engine to controller communication error (no answer).	<ul style="list-style-type: none"> Examine the connection between the controller and the engine board. Replace the engine board if the error is frequent.
670	Engine response error	<ul style="list-style-type: none"> Engine board installed incorrectly Engine board defective Controller board defective
671	Controller-to-operation panel communication error at startup	<ul style="list-style-type: none"> Controller stalled Controller board installed incorrectly Controller board defective Operation panel connector loose or defective
800	Video data error	<ul style="list-style-type: none"> Examine the connection between the controller and the engine board. Replace the engine board if the error is frequent.
818	System timeout error	<ul style="list-style-type: none"> Defective controller Replace the controller if it occurs frequently.
819	Kernal end error	<ul style="list-style-type: none"> HDD error Software application error RAM shortage
820	Controller CPU error	<ul style="list-style-type: none"> Replace the controller if the error is frequent.
821	CPU and ASIC timer error	<ul style="list-style-type: none"> Turn off the machine and turn it back on. Replace the controller if the error is frequent.
822	HDD timeout error	<ul style="list-style-type: none"> Examine the connection between the HDD and the controller Replace the HDD if the error is frequent.
823	NIB self test error	<ul style="list-style-type: none"> Turn off the machine and turn it back on. Examine the connection between the NIB and the controller. Replace the NIB if the error is frequent.
824	NVRAM error	<ul style="list-style-type: none"> Replace the NVRAM if the error is frequent.
827	SDRAM error	<ul style="list-style-type: none"> Replace the controller if the error is frequent.
828	Flash ROM error	<ul style="list-style-type: none"> Replace the controller if the error is frequent.
829	Optional RAM error	<ul style="list-style-type: none"> Examine the connection of the optional memory. Replace the optional memory if the error is frequent.
835	Parallel interface error	<ul style="list-style-type: none"> Replace the controller if the error is frequent.
836	Font ROM error	<ul style="list-style-type: none"> Not used for this model.
837	Optional font ROM error	<ul style="list-style-type: none"> Not used for this model.
838	Clock generator error	<ul style="list-style-type: none"> Replace the controller if the error is frequent.

Code	Description	Required Action
850	NIB interface error	<ul style="list-style-type: none"> Replace the controller if the error is frequent.
851	IEEE1394 interface error	<ul style="list-style-type: none"> Replace the controller if the error is frequent.
853	Wireless LAN Error: Card Error 1	<ul style="list-style-type: none"> Wireless LAN card not inserted into the wireless LAN board
854	Wireless LAN Error: Card Error 2	<ul style="list-style-type: none"> Wireless LAN card has been removed
855	Wireless LAN Error: Card Error 3	<ul style="list-style-type: none"> Wireless LAN card defective Wireless card connection not tight
856	Wireless LAN Error 4: Board	<ul style="list-style-type: none"> Wireless LAN card board defective PCI connector loose
857	USB I/F Error	<ul style="list-style-type: none"> The USB driver can generate three types of errors: RX, CRC, and STALL errors. Only the STALL error can generate this SC code. Defective controller board
860 G116 Only	HDD start-up error	<ul style="list-style-type: none"> Turn off the machine and turn it back on. Examine the connection between the HDD and the controller. Replace the HDD if the error is frequent.
862	HDD damaged cluster error	<ul style="list-style-type: none"> Replace the HDD if the error is frequent.
863	HDD data unable to read	
864	HDD data access error	
865	HDD access error	
900	Controller counter error	<ul style="list-style-type: none"> Replace the NVRAM if the error is frequent.
955	FGATE error The IPU does not respond with the settings required to start memory image processing.	<ul style="list-style-type: none"> Software bug; reboot the machine Internal parameter incorrect Insufficient working memory
990	Software performance error	<ul style="list-style-type: none"> Software defective; reboot the machine Internal parameter incorrect Insufficient working memory When this SC occurs, the file name, address, and data will be stored in NVRAM. <p>Note the above data and the situation in which this SC occurs. Then report the data and conditions to your technical control center.</p>
991	Software continuity error	<ul style="list-style-type: none"> Software bug; reboot the machine Internal parameter incorrect Insufficient working memory
998	Application start error	<ul style="list-style-type: none"> Software defective; change the firmware for the application that failed An option required by the application (RAM, DIMM, board) is not installed
999	Software update error	<ul style="list-style-type: none"> Try downloading the controller software again.

4.3 ELECTRICAL COMPONENT DEFECTS

4.3.1 SENSORS

Refer to the G091/G094/G095 Service Manual for details.

4.3.2 SWITCHES

Refer to the G091/G094/G095 Service Manual for details.

4.4 BLOWN FUSE CONDITIONS

Refer to the G091/G094/G095 Service Manual for details.

4.5 LEDS

Refer to the G091/G094/G095 Service Manual for details.

5. SERVICE TABLES

5.1 SERVICE PROGRAM MODE [G112/G113/G116]

The Service Program Modes in this section are for the G112/G113/G116 machines. Differences that are machine specific show in the margin with the machine code.

⚠ CAUTION

Do these before you go into the service program mode:

- Make sure there is no print data in the printer buffer (the Data In LED must not be lit or blinking).
- If there is some data in the buffer, wait until all data has been printed.

5.1.1 ENABLING AND DISABLING SERVICE PROGRAM MODE

Entering the Service Mode

There are two ways to enter the service mode.

Method 1: Turn the machine on while pressing the “On Line” key and “Escape” key together until “1. Service Menu1” shows on the display.

NOTE: If you switch the machine off, any jobs stored on the hard disk using the sample print and protected print features will be deleted.

Check first with the user tools to see if there are any jobs stored with these features
(Menu key - Sample Print, or Protected Print).

Method 2: Press the “Up/Down arrow” keys together for about 5 seconds. Then press the “Enter” key.

“1. Service Menu1” shows on the display.

NOTE: The machine automatically goes off line when you enter the service mode

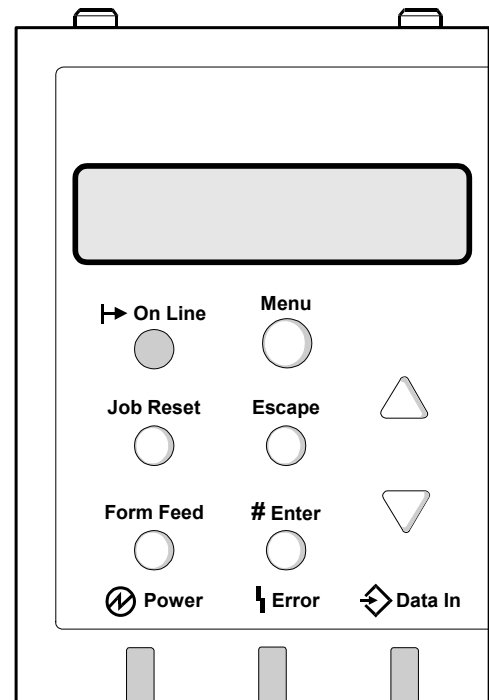

G116S509.WMF

Inputting a Value or Setting for a Service Program

Enter the required program mode as explained above. The setting that shows on the display is the current setting.

Select the required setting with the “Up/Down arrow” keys. Then press the “Enter” key. The previous value stays if the “Enter” key is not pressed.

Exiting Service Mode

Select “3. End” from the service mode main menu. Then press the “Enter” key.

5.2 PRINTER CONTROLLER SERVICE MODE [G112/G113/G116]

5.2.1 SERVICE MODE MENU (“1. SERVICE MENU”)

Service Mode	Description	Function
1001	Bit switch	Adjusts bit switch settings. Note: Currently the bit switches are not being used.
1003	Clear Setting	Initializes settings in the “System” menu of the user mode.
1004	Print summary	Prints the service summary sheet (a summary of all the controller settings).
1005	Disp Version	Displays the version of the controller firmware.

5.2.2 BIT SWITCH PROGRAMMING [G112/G113/G116]

NOTE: At this time, the bit switches are not used.

1. Enter the SP mode with “Service Menu”. Then press [Enter] twice.

```
Service Menu
BitSW
```

2. Select #1, #2, #3, or #4 for the desired bit switch. Then press [Enter].

```
BitSW
<BitSW#1>
```

- [▲] [▼]: Move to the next switch.

3. Adjust the bit switch with these keys:

- [▲] [▼]: Move to the next bit.
- [Escape]: Exit without saving changes.
- [Enter]: Exit and save changes.

```
Sw#1  00000000
Bit0   _
```

NOTE: The left digit on the display is bit 7 and the right digit is bit 0.

4. Press [Enter] to save changes and exit.

5.3 PRINTER ENGINE SERVICE MODE [G112/G113/G116]

5.3.1 SERVICE MODE TABLE

Notation	What it means
[range / default / step]	Example: [-9 ~ +9 / +3.0 / 0.1 mm step]. The setting can be adjusted in the range ± 9 , value reset to +3.0 after an NVRAM reset, and the value can be changed in 0.1 mm steps with each key press.
Italics	Comments added for reference.
DFU	Denotes "Design or Factory Use". Do not change this value.
Japan only	The feature or item is for Japan only. Do not change this value.

SP1-xxx: Feed

1003	Regist sag	
	Adjusts the relay clutch timing at registration. Relay clutch timing determines the amount of paper buckle at registration. (A "+" setting causes more buckling.)	
1003 1	Cassette	[-8 mm ~+8 mm/ 0 /2 mm step]
1003 2	Multi tray [By-pass]	[-8 mm ~+8 mm/ 0 /2 mm step]
1003 3	Duplex Tray	[-8 mm ~+8 mm/ 0 /2 mm step]

1104	Fusing control	Normal , Phase control
	Use phase control if the room lights flicker when the fusing lamp starts. Defaults: North America – Normal (On/off control), Europe – Phase	

1105	Fusing Temp.	
	Adjusts the fusing temperatures for printing and standby mode.	
1105 1	Fusing temp	[150 ~ 200/ 170 / 5 deg.] DFU
	Adjusts the fusing temperature for printing on normal paper.	
1105 2	Fusing T Stand	[140 ~ 175 / 168 / 1 deg.] DFU
	Adjusts the fusing temperature for standby mode.	

1106	Fusing T Display
1106 1	Displays the current fusing temperature.

1902	OHP clutch rt	G112/G113 1 = 1 rotation , 2 = 2 rotations
		G116 1 = 1 rotation, 2 = 2 rotations
Selects the number of rotations for the bypass feed roller when the paper type is set to "Transparencies".		
If jams occur when transparencies are being used, change the setting to 2.		

1910	Fusing start	Normal , Roller turn DFU
	Roller turn: Warms up the fusing unit for 20 s just after the power switch has been turned on or when the machine warms up from energy saver mode. Normal: There is no 20 s warm-up period. However, just after the main power switch is turned on, the motor turns to clean the drum. NOTE: This SP mode is effective only when the internal temperature is less than 15 C.	

1912 (G116)	Warm up control	Normal , Curl control
	Lowers the fusing temperature (to 150°C) to prevent thin paper from curling. Use this mode only when a paper jam occurs during duplex rear side printing.	

SP2-xxx: Drum

2001 (G112/G113)	Charge rol bias	[1000 ~ 2000 / -1700V / 10V step] DFU
	Adjusts the voltage applied to the charge roller for printing.	

2001 (G116)	Charge rol bias	[1005 ~ 1995 / -1675V / 10V step] DFU
	Adjusts the voltage applied to the charge roller for printing.	

2112	Mainscan mag	[-0.5% ~ 0.5% / 0 / 0.1% step]
	Adjusts the main scan magnification.	

2113	Subscan mag	[-0.5% ~ 0.5% / 0 / 0.1% step]
	Adjusts the sub scan magnification.	

2201	Developer bias	[200 ~ 800 / 750V / 10V step] DFU
	Adjusts the development bias for printing.	

2213	Toner end count	[50 ~ 200 / 200 / 50 sheets/step]
	Adjusts the number of prints the machine can make after it detects toner near-end.	

2301	Transfer curr	[-2 ~ 4 / 0 / 2 μA/step]
	Adjusts the correction current applied to the transfer roller.	

2902	Test Pattern	
	Printing Test Pattern	No specified Various test patterns
	Selects a printer test pattern. After selecting a pattern, the display automatically goes to SP 5902. Use SP 5902 to print either one test pattern (5902-1) or a few of them (5902-2). <i>Reset SP 2902 to "no specified" after printing the test pattern, or the selected pattern will appear on every page printed by the user.</i>	

2910	Thermistor adj	No, Yes
	If this is "Yes", the machine automatically adjusts the charge roller voltage and transfer current in response to the temperature within the machine.	

2928	Toner end clear	Execute DFU
	Clears the toner end counter in the engine board. Not used in this machine.	

2980	Waste toner cnt	
	Displays the waste toner counter in the engine board.	

SP3-xxx: Process

3921	Effective info	Not used: All items ignored Cartridge dtct: Cartridge detection only Normal mode (Cartridge detection and Type ID) All used: All items used
	Selects which of the cartridge ID chip functions are enabled.	

3922	Cartridge lmt	G116: [15k ~ 40k / 30k / 5k step] G112/G113: [15k ~ 40k / 20k / 5k step]
	Adjusts the number of prints the machine can make after a new cartridge is detected. Do not use a higher value than 30 k, or waste toner could leak from the waste toner tank.	

3923	Cartridge stop	No, Yes
	Determines whether the machine stops printing after the cartridge counter reaches the limit set with SP 3922.	

3924	Toner end sensor	
3924 1	Toner near-end	[100 ~ 1000 / 200 / 100 ms step] DFU
	Threshold adjustment for toner near-end detection.	
3924 2	Toner end	[250 ~ 1050 / 550 / 100 ms step] DFU
	Threshold adjustment for toner end detection	

3925	Cartridge info
3925 1	Machine ID
	Displays the model name stored in the toner cartridge IC chip.
3925 2	Cartridge Version
	Displays the cartridge version number stored in the toner cartridge IC chip.
3925 3	Brand ID
	Displays the OEM brand name stored in the toner cartridge IC chip.
3925 4	Color ID
	Displays the cartridge color name stored in the toner cartridge IC chip.
3925 5	Area ID
	Displays the region stored in the toner cartridge IC chip.
3925 6	Kind ID
	Displays the part code number stored in the toner cartridge IC chip.
3925 7	Secu ID
	Displays the cartridge type ID stored in the toner cartridge IC chip.
3925 8	Maker ID
	Displays the maker ID number stored in the toner cartridge IC chip.

3926 (G112/G113)	Prevention of filming	No, Yes
	<p>If set to "Yes": This is done every 50 prints, for 0.2 s, to lubricate the cleaning blade. The charge roller voltage is cut, and toner is transferred to the cleaning blade. If the 50-print interval is reached during a job, printing stops and this process is done.</p> <p>Set this to yes to prevent the following:</p> <ul style="list-style-type: none"> • Grey banding parallel to the paper feed direction • Cleaning blade flipping due to friction between blade and drum • Noise due to friction between blade and drum 	

SP5-xxx: Mode

5024	mm/inch Display Selection	0: Europe/Asia (mm), 1: North America (inch)
	<p>Selects the unit of measurement.</p> <p>After selection, turn the main power switch off and on.</p>	

5104 (G116)	Double Count	Specifies whether the counter is doubled for A3/11" x 17" paper. If "Yes" is selected, the total counter counts up twice when A3/11" x 17" paper is used.
		<p>Yes (double count)</p> <p>No (single count)</p>

5302	Set Time	[-1440 ~ 1440 / Montreal: -300 /1 minute/step] DFU
	<p>Adjusts the RTC (real time clock) time setting. Sets the local time. (Montreal: -300, Paris: +60, Beijing: +480, Taipei: +480, Hong Kong: +480)</p>	

5307	Summer time	
5307 1	Setting	Enables or disables the summer time mode. [0 to 1 / 0 / -] Alphanumeric 0: Off, 1: On
5307 3	Rule set (Start)	Specifies the start of the daylight saving time.
5307 4	Rule set (End)	Specifies the end of the daylight saving time

5404	[UcodeCtrClr] User Code Counter Clear	
5404 1	UcodeCtrClr	Clears all counters for users.

5501	PM Alarm. PM alarm level	
	Sets the PM alarm level. A PM alarm is made when this condition occurs: PA x 1000 = or > PC, where PA is the value set in SP5-501 and PC is the value in the PM counter. [0 to 9999 / 0 / -] The alert is sent to the e-mail address that is specified for the system administrator using a browser and the built-in web server (Web Image Monitor). 0: Disables the PM alarm When SP 5866 1 is set to 1, this SP is enabled.	

5504	Jam Alarm	
	Sets the jam alarm level. If a paper jam occurs, the jam alarm counter increases by +1. If no paper jam occurs while the set number of paper is output, the jam alarm counter decreases by -1. The jam alarm occurs when the jam alarm counter gets to +10. [0 to 3 / 3 / 1/step] 0: Disables the jam alarm 1: 1.5K, 2: 3K, 3: 6K The alert is sent to the e-mail address that is specified for the system administrator using a browser and the built-in web server (Web Image Monitor). When SP 5866 1 is set to 1, this SP is enabled.	

5505	Error Alarm	
	Occurs, the error alarm counter increases by +1. If no SC code occurs while the set number of paper is output, the jam alarm counter decreases by -1. The error alarm occurs when the error alarm counter reaches +5. [0 to 255 / 18 / 1/step] 0: Disables the PM alarm The alert is sent to the e-mail address that is specified for the system administrator using a browser and the built-in web server (Web Image Monitor). When SP 5866 1 is set to 1, this SP is enabled.	

5507	Supply Alarm	
5507 1	Paper Supply Ala	Enables or disables the supply alarm. [0 to 1 / 0 / -] Alphanumeric 0: Off, 1: On
5507 3	Toner Supply Alarm	
5507 128	Interval: Others	Sets the paper supply alarm level. A paper supply alarm counter increases by +1 when a sheet of the related size is used. The paper supply alarm occurs when one of the paper supply alarm counters gets to the set value. [250 to 10000 / 1000 / 1/step] The alert is sent to the e-mail address that is specified for the system administrator using a browser and the built-in web server (Web Image Monitor). When SP 5866 1 is set to 1, this SP is enabled.
5507 132 (G116)	Interval: A3	
5507 133	Interval: A4	
5507 134	Interval: A5	
5507 141 (G116)	Interval: B4	
5507 142	Interval: B5	
5507 160 (G116)	Interval: DLT	
5507 164	Interval: LG	
5507 166	Interval: LT	
5507 172	Interval: HLT	

5801	Memory Clear
	Resets software counters and returns modes and settings to their defaults. All clear: Clears all data Engine clear: Clears the printer engine settings SCS: Clears the systems settings PRT: Clears user mode system settings NCS: Network control systems - Clears the items listed in the "Host Interface" section of the Configuration page. DCS: Delivery control system (e-mail settings) MIRS: E-mail addresses
5801 1	Memory all clear
5801 2	Engine memory clear
	Resets the following user tool settings: Maintenance menu: Main scan registration, sub scan registration, image density, curl control Resets the settings of the following SPs: 1003, 1104, 1105, 1902, 1910, 2001, 2112, 2113, 2201, 2213, 2301, 2910, 3921, 3922, 3923, 3924, 5930
5801 3	SCS memory clear
	Resets the following user tool settings: Paper Input menu: Paper type, paper size, tray lock, System menu: Energy saver timer Resets the settings of the following SPs: 5009, 5812 Also resets the user code counters.
5801 4	IMH: Clears IMH data. DFU
5801 5	MCS: Clears MCS data DFU
5801 8	PRT memory clear
	Resets the following user tool settings: Paper Input menu: Tray priority System menu: Misfeed recovery, print error report, auto continue, memory overflow, output tray, job separation, memory usage
5801 10	Web Service Clears the web service data and the network application data.

5801 11	NCS memory clear Resets the network settings, such as IP address and subnet mask
5801 14	DCS setting Resets the e-mail settings, such as those stored in SP 5860
5801 15	Clear USC Settings Resets or deletes the UCS-related data.
5801 16	MIRS setting Resets the settings used for the e-mail alert feature (such as the enable/disable setting and the address used for the e-mail alert)
5801 17	CCS Resets or deletes the CSS-related data. FA

5802	Free run
	The machine performs a free run. Press [Enter] to start. Press [Enter] to stop. Please note that the machine will not stop immediately after the [Enter] key is pressed.

5803	Input check	
	Displays signals received from sensors and switches. NOTE: SP Modes other than those listed in this table, are not used in the machine.	
	Operation Panel	Component Name
5803 1	Front Door	Front cover safety switch
5803 2	MainMotLock	Main Motor Lock
5803 3	PolygonLock	Polygon Motor Lock
5803 5	Duplex door	Duplex Unit cover switch
5803 6	Duplex set	Duplex Unit
5803 7	Fusing set	Fusing Unit
5803 11	StdTrayFul	Paper Overflow Sensor
5803 16	Regist	Registration Sensor
5803 17	Pap Output	Paper Exit Sensor
5803 18	Dup in/out	Duplex Inverter Sensor
5803 19	Dup In	Duplex Entrance Sensor
5803 20	Duplex Out	Duplex Exit Sensor
5803 21	PinBypass	Bypass paper sensor
5803 22	NoT1paper	Paper end sensor-Standard Paper Tray Unit
5803 23	Tray1 Size	Paper size switch-Standard tray
5803 24	T1 Remains	Remaining paper sensor-Standard tray
5803 26	No T2 paper	Paper end sensor-1st Optional Paper Tray Unit
5803 29	No T3 paper	Paper end sensor-2nd Optional Paper Tray Unit
5803 30	Tray 3 Size	Paper size switch-2nd Optional Paper Tray Unit
5803 31	T3 remains	Remaining paper sensor-2nd Optional Paper Tray Unit
5803 32	Carrier 2	Paper feed sensor-1st Optional Paper Tray Unit
5803 33	Carrier 3	Paper feed sensor-2nd Optional Paper Tray Unit
5803 34	Tray 2 size	Paper size switch-1st Optional Paper Tray Unit

5803	Input check	
	Displays signals received from sensors and switches. NOTE: SP Modes other than those listed in this table, are not used in the machine.	
	Operation Panel	Component Name
5803 36	Tray2 Remains	Remaining paper sensor-1st Optional Paper Tray Unit

The following SP modes are for the G116 model only.		
5803 41	Exit Door	Paper output tray cover sensor
5803 42	Sft Carrier	Not used in this machine
5803 43	Sft to R	Not used in this machine
5803 44	Sft to L	Not used in this machine
5803 45	Paper in Bin 1	Paper in the standard paper tray
5803 46	Bin 1 Full	Standard paper tray full
5803 47	Paper in Bin 2	Paper in the first optional paper tray unit
5803 48	Bin 2 Full	First optional paper tray unit full
5803 49	Paper in B3	Paper in the second optional paper tray unit
5803 50	Bin 3 Full	Second optional paper tray unit full
5803 51	Paper in B4	Not used in this machine
5803 52	Bin 4 full	Not used in this machine
5803 53	4 Bin Upr Tray	Not used in this machine
5803 54	4 Bin lwr Tray	Not used in this machine

5804	Output check	
	Turns on electrical components individually for test purposes. NOTE: SP Modes other than those listed in this table, are not used in the machine.	
	Operation Panel	Component Name
5804 0	Impossible	Not used in this machine
5804 1	Main Motor	Main Motor
5804 2	Carr Clutch	Relay Clutch
5804 3	Reg Clutch	Registration Clutch
5804 5	Tray1 Clutch	Paper Feed Clutch
5804 6	Byp Clutch	Bypass Feed Solenoid
5804 11	Fan/speedy	Exhaust fan
5804 12	Fan/slowly	Exhaust fan
5804 13	Fus Relay	Fusing Lamp Relay
5804 22	Pol Motor	Polygon Motor
5804 23	Pol + LD	Polygon Motor and Laser Diode
5804 26	T2 Clutch	Paper Feed Clutch-1st Optional Paper Tray Unit
5804 27	T2 Motor	Paper Tray Motor-1st Optional Paper Tray Unit
5804 28	T3 Clutch	Paper Feed Clutch-2nd Optional Paper Tray Unit
5804 29	T3 Motor	Paper Tray Motor-2nd Optional Paper Tray Unit

5804 31 (G116)	Exit motor.	Exit motor
5804 32 (G116)	Exit solenoid.	Paper exit junction gate solenoid
5804 34	Motor to L	Not used in this machine
5804 35	SP1 Solenoid	Not used in this machine
5804 36	SP2 Solenoid	Not used in this machine
5804 37	SP3 Solenoid	Not used in this machine
5804 41	Dup Side Rt.	Duplex Inverter Motor-forward
5804 42	Dup Side Rv	Duplex Inverter Motor-reverse
5804 43	Dup Long	Duplex Transport Motor
5804 44	Dup Split	Inverter Gate Solenoid

5810	Fusing err clear
	Resets a service call condition (for fusing unit errors). After using this SP mode, turn the main switch off and on.

5811	Machine Number DFU
	Used to input the machine serial number. This is normally done at the factory. If you want to know the serial number, print the system parameter list. Press  and then input "A".

5812	Service Tel. No. Setting	
	Use these SP modes to input service and support telephone numbers. Enter the number and press Press the  key to input a pause. Press the "Clear modes" key to delete the telephone number.	
5812 1	Service	Use this to input the telephone number of the CE printed on the SP print mode printout.
5812 2	Fax	Use this to input the fax number of the CE printed on the SP print mode printout.

5816	Remote Service	
5816 1	I/F Setting	[0 to 2 / 2 / 1/step] Alphanumeric 0: Off, 1: CSS 2: Network (The remote service function is on.)
5816 2	CE Call	[0 to 1 / 1 / 1/step] 0: Start, 1: End
5816 3	Function Flag	[0 to 1 / 0 / 1/step] 0: Off (The remote service function is disabled.) 1: On (The remote service function is enabled.)

5816 4	Communication Test	Does a communication test. One of the return codes from 0 to 99 is shown: <ul style="list-style-type: none"> • 0: Normal end (The service is operating.) • 1: Normal end (The service is not operating.) • Any other code: Abnormal end Do the test from the User Tools. Do not use SP 5816 4 unless you are told to do it by the manufacturer.
5816 5	Device Information	DFU
5816 6	Device Information	Shows or does not show the device information in the User Tools. [0 to 1 / 0 / 1/step] 0: Not displayed, 1: Displayed
5816 7	SSL Disable	[0 to 1 / 0 / 1/step] 0: On, 1: Off
5816 8	RCG Connect Time	Sets the timeout counter for the remote connection. [1 to 90 / 10 / 1 second/step]
5816 9	RCG Write Timeout	Sets the timeout counter for writing processing. [0 to 100 / 60 / 1 second/step]
5816 10	RCG Read Timeout	Sets the timeout counter for reading processing. [0 to 100 / 60 / 1 second/step]
5816 11	Port 80 Enable	Enables or disables access to the SOAP method via port 80. [0 to 1 / 0 / 1/step] 0: Disables, 1: Enables

5821	Remote Service Address	
5821 1	CSS-PI Device Co	[0 to 4 / 0 / 1/step] DFU
5821 2	RCG IP Address	Sets the IP address of the RCG (Remote Communication Gate). [00000000h to FFFFFFFFh / 00000000h / 1/step]

5824	NVRAM Upload	
	# Uploads the UP and SP mode data (except for counters and the serial number) from the NVRAM to an SD card.	

5825	NVRAM Download	
	# Downloads the UP and SP mode data from an SD card to the NVRAM.	

5828	Network	
5828 50	1284 Compatible	Switches Centronics IEEE1284 compatibility on/off for the network. [0 or 1 / 1 / -] 0: Disabled, 1: Enabled Selecting "0" disables bi-directional data transmission.

5828 52	ECP	Switches the ECP setting for Centronics off/on. [0 or 1 / 1 / -] 0: Disabled, 1: Enabled With "1" selected, SP5-828-050 must be enabled for 1284 mode compatibility.
5828 65	Job Spool	Switches the job spool on/off. [0 or 1 / 0 / -] 0: Disabled, 1: Enabled
5828 66	HDD Job Clear	Selects the treatment of the job when a spooled job exists at power on. [0 to 1 / 1 / 1/step] 0: Data is cleared, 1: Automatically printed
5828 69	Job Spool Protocol	Switches job spooling off or on and enables settings for job spooling protocols. [0 to 1 / 1 / 1/step] 0: Off, 1: On
5828 84	Print Settings List	Prints a list of NCS related parameters.
5828 90	Telnet	Enables or disables Telnet. [0 to 1 / 1 / 1/step] 0: Disabled, 1: Enabled
5828 91	Web	Enables or disables the Web monitor. [0 to 1 / 1 / 1/step] 0: Disabled, 1: Enabled

5832	HDD Init	
	Initializes the hard disk. Use this only if there is a hard disk error.	

5837	Prog checksum	
	Displays the checksum for the engine firmware.	

5839	IEEE1394	
5839 004	Host name	DFU
5839 007	Cycle master	DFU
5839 008	BCR mode	DFU
5839 009	IRM 1394a check	DFU
5839 010	Unique ID	DFU
5839 011	Logout	DFU
5839 012	Login	DFU
5839 013	Login max	DFU

5840	IEEE802.11b	
5840 06	Channel max	DFU
5840 07	Channel min	DFU
5840 11	WEP key number	Selects the WEP key number

Service Tables

5842	NFA Analysis	
	Prints or does not print the module log for each bit. [0 to 1 / 1 / 1/step] 0: Prints, 1: Not print	

5844	USB	
5844 1	Transfer rate	FS Fixation: Full Speed (Fixed) HS/FS Auto : High Speed/Full Speed (Automatic change)
	Sets the speed for USB data transmission.	
5844 2	Vendor ID	DFU
5844 3	Product ID	DFU
5844 4	Dev release number	DFU

5845	Delivery Server Setting	
	Provides items for delivery server settings.	
5845 3	Retry Interval	[60~900 / 300 / 1]
	Determines the time interval between retries before the machine returns to standby after an error occurs during an image transfer with the delivery scanner or SMTP server.	
5845 4	Number of Retries	[0~99 / 3 / 1]
	Determines the number of retries before the machine returns to standby after an error occurs during an image transfer with the delivery or SMTP server.	

5846	UCS Setting	
5846 3	Maximum Entries	Displays the number of maximum entries. 500
5846 50	Init All Dir	Initializes all address information data except the administration account.

5848	Web Service	
5848 4	ac: ud	Enables or disables the udirectory access limitation. 0000: Disabled, 0001: Enabled
5848 11	ac: dm	Enables or disables the device management access limitation. 0000: Disabled, 0001: Enabled

5856	Remote Program Update: Local port. (☛ G091/G094/G095 Section 5.5)	
	When set to “enable” allows reception of firmware data via the local port (IEEE 1284) during a remote ROM update. Disable, Enable This setting is reset to “disable” after the machine is cycled off and on	

5857	Save Debug Log: Not used	
	Do not change the setting.	

5858	Debug Log Save Function: Not used
Do not change the setting.	

5859	Debug Log Save Key No.: Not used
Do not change the setting.	

5860	SMTP/POP3/IMAP	
5860 2	SMTP srv port no.	Input the SMTP server port number
5860 3	SMTP auth	SMTP authentication enable/disable
5860 6	SMTP auth encryp	Encryption mode for SMTP authentication enable/disable (Only valid if 5860 3 is set to "enable")
5860 7	POP before SMTP	Enable/disable POP before SMTP. If the SMTP server does not have authentication, you can enable POP before SMTP, then POP authentication is available (SP 5860 13)
5860 8	POP to SMTP wait	When using POP before SMTP, this SP mode determines the maximum wait time between POP authentication and connection with SMTP. Communication stops if this time is exceeded.
5860 9	Rcv Protocol	Sets the protocol of receiving e-mail. [0 to 2 / 0 / 1/step] 0: Not receive, 1: POP3, 2: IMAP4
5860 13	POP auth encryp	If POP before SMTP is enabled, then you can use this SP to enable or disable encryption mode for POP authentication
5860 14	POP serv port no.	Input the POP server port number
5860 15	IMAP Srv Port No	Adjusts the port number of the IMAP4 server. [1 to 65535 / 143 / 1/step]
5860 17	Receive Interval	Adjusts the interval of receiving an e-mail. [2 to 1440 / 3 / 1 minute/step]
5860 19	Mail keep Sett.	Sets the way of keeping the e-mail in the server. [0 to 2 / 0 / 1/step] 0: Not keeping 1: Keeping All 2: Keeping the only error e-mail
5860 20	Part. Mail Rcv Tm	Adjusts the time for keeping the partial e-mails. If the partial e-mails are not received during the set time, these are deleted. [1 to 168 / 72 / 1 h/step]
586021	MDN Res RFC 2298	[0 or 1 / 1 / -]
5860 22	SMTP from replace	If SMTP authentication is enabled, this SP mode determines which name is included in the e-mail header 0: Normal sender name 1: User name used by the authentication feature

5860	SMTP/POP3/IMAP	
5860 25	SMTP Auth Direct	<p>Selects directly the way of SMTP authentication if all SMTP authentications fail due to the error in the SP5860-006.</p> <p>This SP is activated only when SP5860-003 is set to "Enable".</p> <p>Bit switch 0: LOGIN Bit switch 1: PLAIN Bit switch 2: CRAM MD5 Bit switch 3: DIGEST MD Bit switch 4 - 7: Not used</p>

5866	E-mail Alert	
5860 1	Notice Func Email	<p>Enables or disables the alert notice function by e-mail.</p> <p>[0 to 1 / 0 / 1/step] 0: Off, 1: On</p>
5860 5	Add Date Field	<p>Enables or disables to add the date field on the alert notice e-mail.</p> <p>[0 to 1 / 0 / 1/step] 0: Off, 1: On</p>

5869	RAM disk setting	DFU
------	------------------	-----

5870	Common Key Info. Common key information writing	
5870 1	Writing	Writes the authentication data (used for NRS) in the memory.
5870 3	Initialize	Initializes the authentication data in the memory.

5873	SD Card Appli Move	
5873 1	Move Exec	☛ 5.11.2
5873 2	Undo Exec	☛ 5.11.3

5876	Security Clear	
5876 1	All Clear	
5876 11	Clear NCS Security	
5876 15	Clear UCS Security	

5902	Test print	
	Prints the test pattern that you selected with SP 2902.	
5902 1	1 sheet test	
	Prints one copy of the test pattern	
5902 2	Cont test	
	Prints consecutive copies of the test pattern	

5907	Plug & Play	
	Sets the brand name and the production name for Windows Plug & Play. This information is stored in NVRAM. If the NVRAM is defective or has been replaced, these names should be registered again. To set the plug and play model name, enter the model number, and then press (#).	

5930	Meter charge mode	No, Yes
	Enables or disables meter-charge mode. Important: Turn the main switch off/on after changing this setting. Meter charge mode enabled: <ul style="list-style-type: none"> • “Replace Maintenance Kit” is not displayed on the operation panel when the PM counter runs out (the technician replaces the maintenance kit items) • The meter charge counter is shown immediately after the Menu key is pressed. • The technician must reset the PM counter after finishing PM. Meter charge mode disabled: <ul style="list-style-type: none"> • “Replace Maintenance Kit” is displayed on the operation panel when the PM counter runs out (the user replaces the maintenance kit items) • The meter charge counter is not shown when the Menu key is pressed. • The PM counter resets automatically after the user replaces the fusing unit. 	

5983	Paper Kind Setting	
	Sets the engine parameters used by the machine when “special paper” is selected as the paper type 0: “Plain paper” parameters 1: “Thick paper” parameters	

5990	SP print mode	
5990 1	All (Data List)	Prints summary sheet for the item selected.
5990 2	SP (Mode Data List)	
5990 4	Logging	
5990 5	Diagnostic Report	
5990 6	Non-default	
5990 7	NIB Summary	

Service Tables

SP7-xxx: Data Log

7001	Operation time	
	Displays the total number of engine rotation cycles made so far. NOTE: 1) One cycle is calculated as 3.8 s (G112/G113) of drum rotation. 2) One cycle is calculated as 3.0 s (G116) of drum rotation. However, this counter also includes idle rotations. This counter is not reset at PM.	

7401	SC Counter	[0 to 9999 / 0 / 1/step]
	Shows the number of SC codes detected.	

7502	Total Jam	[0 to 9999 / 0 / 1 sheet/step]
	Shows the total number of paper jams.	

7504	Jam location	
	Displays the number of jams according to the location where jams were detected.	
7504 17	Main 17	PFU (tray 2) paper feed sensor not turned on
7504 18	Main 18	PFU (tray 3) paper feed sensor not turned on
7504 19	Main 19	Registration sensor not turned on – bypass feed
7504 20	Main 20	Registration sensor not turned on –tray 1
7504 21	Main 21	Registration sensor not turned on –paper feed unit
7504 22	Main 22	Registration sensor not turned on –duplex
7504 23	Main 23	Registration sensor not turned off
7504 24	Main 24	Paper exit sensor not turned on
7504 25	Main 25	Paper exit sensor not turned off
7504 33	Main 33	Not used in this machine
7504 34	Main 34	Not used in this machine
7504 35	Main 35	Not used in this machine
7504 36	Main 36	Not used in this machine
7504 49	Main 49	Duplex entrance sensor not turned on
7504 50	Main 50	Duplex entrance sensor not turned off
7504 51	Main 51	Duplex inverter sensor not turned on
7504 52	Main 52	Duplex inverter sensor not turned off
7504 53	Main 53	Duplex exit sensor not turned on
7504 54	Main 54	Duplex exit sensor not turned off
7504 255	Main 255	Others

7506 (G116)	Jam Paper size	
7506 5	A4 LEF	Displays the number of jams according to the paper size. [0 to 9999 / 0 / 1 sheet/step]
7506 6	A5 LEF	
7506 14	B5 LEF	
7506 38	LTR LEF	
7506 132	A3 SEF	
7506 133	A4 SEF	
7506 134	A5 SEF	
7506 141	B4 SEF	
7506 142	B5 SEF	
7506 160	DLT SEF	
7506 164	LG SEF	
7506 166	LT SEF	
7506 172	HLT SEF	
7506 255	Others	

7506 (G112/G113)	Jam Paper size	
7506 6	A5 LEF	Displays the number of jams according to the paper size. [0 to 9999 / 0 / 1 sheet/step]
7506 44	HLT LEF	
7506 133	A4 SEF	
7506 134	A5 SEF	
7506 142	B5 SEF	
7506 164	LG SEF	
7506 166	LT SEF	
7506 172	HLT SEF	
7506 255	Others	

7801 (G112/G113)	ROM version display	
	Displays the firmware version (system, engine, and duplex).	
7801 1	System Version	
7801 2	Engine Version	
7801 3	Duplex Version	

7803	PM Counter	
	Displays the PM counter. This is not a page counter. It estimates the page count using the engine rotation cycle count. It counts up one page when the engine has made the average number of rotations that is required for one page of a three-page job.	
7803 1	Transfer roller	
7803 2	Paper feed roller	
7803 3	Fusing unit	
7803 255	Paper This SP is controlled by the controller. This counter is a page counter, so the results can be different from SP7803 1-3 (SP7803 1-3 are controlled by the engine and are not page counters; see above). When meter charge mode is on (the technician does PM), use this SP mode with the NRS to check when it is time to do PM.	

7804	PM Counter Reset	
	Resets the PM counter. Important: If a technician replaces the PM items, reset this counter after PM.	
7804 1	Transfer roller	
7804 2	Paper feed roller	
7804 3	Fusing unit	
7804 255	Paper	

7807	[SC/ Jam Clear] SC/ Jam Counter Clear	
7807 1	All Clear	Clears the all counters related to SC codes and paper jams.

Service Tables

7832	Diag Result
	Press # to display a list of error codes. Nothing is displayed if no errors have occurred.

7836	Total Memory Size
7836 1	Shows the total storage size.

7901	Assert Info DFU (Used for debugging.)	
7901 1	File name	DFU
7901 2	# of Lines	DFU
7901 3	Location	DFU

7910	ROM Number	
	Displays the part number of the firmware	
7910 1	System	
7910 2	Engine	
7910 13	Duplex	
7910 18	NIB	
7910 131	Bluetooth	
7910 150	RPCS	
7910 151	PS	
7910 152	RPDL	
7910 153	R98	
7910 154	R16	
7910 155	RPGL	
7910 156	R55	
7910 157	RTIFF	
7910 158	PCL	
7910 159	PCLXL	
7910 160	MSIS	
7910 161	MSIS (option)	
7910 162	PDF	
7910 163	Bmlinks	
7910 180	Font	
7910 181	Font 1	
7910 182	Font 2	
7910 183	Font 3	
7910 200	Factory	
7910 202	Net File	
7910 204	Printer	
7910 209	Test Suite	
7910 210	MIB	
7910 211	Web System	

7911	Firmware version
	Displays the firmware version

7911 1	System	
7911 2	Engine	
7911 13	Duplex	
7911 18	NIB	
7911 131	Bluetooth	
7911 150	RPCS	
7911 151	PS	
7911 152	RPDL	
7911 153	R98	
7911 154	R16	
7911 155	RPGL	
7911 156	R55	
7911 157	RTIFF	
7911 158	PCL	
7911 159	PCLXL	
7911 160	MSIS	
7911 161	MSIS (option)	
7911 162	PDF	
7911 163	Bmlinks	
7911 180	Font	
7911 181	Font 1	
7911 182	Font 2	
7911 183	Font 3	
7911 200	Factory	
7911 202	Net File	
7911 204	Printer	
7911 209	Test Suite	
7911 210	MIB	
7911 211	Web System	

7993	Total counter	
	Displays the engine total counter. It counts up for all prints, including service reports.	

SP8-xxx: Counters

8381	T: 2-2-01	The number of sheets that the application program tries to print (excluding the pages printed in the SP mode) [0~9999999/ 0 / 1]
8384	P: 2-2-01	
8387	O: 2-2-01	

8391	T: 2-2-01	The number of sheets printed on A3/DLT and larger sizes [0~9999999/ 0 / 1]
------	-----------	---

8411	T: 2-2-04	The number of sheets used in duplex printing [0~9999999/ 0 / 1]
------	-----------	--

8421	T: 2-2-05	The number of sheets used in binding and combining [0~9999999/ 0 / 1]
	Mechanical Counter by Print Mode	
8421 1	Simplex> Duplex	Counts pages
8421 4	Simplex Combine	Combine pages
8421 5	Duplex Combine	Combine pages
8421 6	2>	Combines 2 in 1
8421 7	4>	Combines 4 in 1
8421 8	6>	Combines 6 in 1
8421 9	8>	Combines 8 in 1
8421 10	9>	Combines 9 in 1
8421 11	16>	Combines 16 in 1
8421 12	Booklet	Prints books
8421 13	Magazine	Prints magazines

8424	P: 2-2-05	The number of sheets used in binding and combining [0~9999999/ 0 / 1]
	Controller Counter by Print Mode	
8424 1	Simplex>Duplex	Counts pages
8424 4	Simplex Combine	Combine pages
8424 5	Duplex Combine	Combine pages
8424 6	2>	Combines 2 in 1
8424 7	4>	Combines 4 in 1
8424 8	6>	Combines 6 in 1
8424 9	8>	Combines 8 in 1
8424 10	9>	Combines 9 in 1
8424 11	16>	Combines 16 in 1
8424 12	Booklet	Prints books
8424 13	Magazine	Prints magazines

8427	O: 2-2-05	The number of sheets used in binding and combining [0~9999999/ 0 / 1]
	Others by Print Mode	
8427 1	Simplex> Duplex	Counts pages
8427 4	Simplex Combine	Combine pages
8427 5	Duplex Combine	Combine pages
8427 6	2>	Combines 2 in 1
8427 7	4>	Combines 4 in 1
8427 8	6>	Combines 6 in 1
8427 9	8>	Combines 8 in 1
8427 10	9>	Combines 9 in 1
8427 11	16>	Combines 16 in 1
8427 12	Booklet	Prints books
8427 13	Magazine	Prints magazines

8441	T: 2-2-07	The number of sheets of a specific paper size that the application program uses [0~9999999/ 0 / 1]
	Mechanical Total Counter by Page Size	
8441 1	A3	
8441 2	A4	
8441 3	A5	
844 1 4	B4	
8441 5	B5	
8441 6	DLT	
8441 7	LG	
8441 8	LT	
8441 9	HLT	
8441 10	12 x 18/ 13 x 19	
8441 254	Others: Fixed	
8441 255	Others: Custom	

8444	P: 2-2-07	The number of sheets of a specific paper size that the application program uses [0~9999999/ 0 / 1]
	Controller Count by Page Size	
8444 1	A3	
8444 2	A4	
8444 3	A5	
8444 4	B4	
8444 5	B5	
8444 6	DLT	
8444 7	LG	
8444 8	LT	
8444 9	HLT	
8444 10	12 x 18/ 13 x 19	
8444 254	Others: Fixed	
8444 255	Others: Custom	

8447	O: 2-2-07	The number of sheets of a specific paper size that the application program uses [0~9999999/ 0 / 1]
	Others Count by Page Size	
8447 1	A3	
8447 2	A4	
8447 3	A5	
8447 4	B4	
8447 5	B5	
8447 6	DLT	
8447 7	LG	
8447 8	LT	
8447 9	HLT	
8447 10	12 x 18/ 13 x 19	
8447 254	Others: Fixed	
8447 255	Others: Custom	

Service Tables

8451	2-2-08	The number of sheets fed from a specific tray [0~9999999/ 0 / 1]
	Counter by Tray	
8451 1	Bypass Tray	
8451 2	Standard Tray	
8451 3	1st optional tray	
8451 4	2nd optional tray	
8451 5	Tray 4	Not used in this machine
8451 6	Tray 5	Not used in this machine
8451 7	Tray 6	Not used in this machine
8451 8	Tray 7	Not used in this machine
8451 0	Tray 8	Not used in this machine

8461	T: 2-2-09	The number of sheets of specific paper types [0~9999999/ 0 / 1]
	Counter by Paper Type	
8461 1	Normal	
8461 2	Recycled	
8461 3	Special	
8461 4	Thick	
8461 5	Normal (Front)	
8461 6	Thick (Back)	
8461 7	OHP	
8461 8	Other	

8464	P: 2-2-09	The number of sheets of specific paper types [0~9999999/ 0 / 1]
	Controller Counter by Paper Type	
8464 1	Normal	
8464 2	Recycled	
8464 3	Special	
8464 4	Thick	
8464 5	Normal (Front)	
8464 6	Thick (Back)	
8464 7	OHP	
8464 8	Other	

8521	T: 2-2-15	The number of pages processed by the finisher [0~9999999/ 0 / 1]
	Total Edit by Print Mode	
8521 7	Not used in this machine	Not used in this machine

8524	P: 2-2-15	The number of pages processed by the finisher [0~9999999/ 0 / 1]
	Total Controller Edit by Print Mode	
8524 1-6	Not used in this machine	Not used in this machine
8524 7	Others	Not used in this machine

8581	T: Admin Counter	The number of outputs in a specific color mode [0~9999999/ 0 / 1]
	Total Counter	
8581 1	Total	Not used in this machine

8591	O: 2-2-23	The number of A3/DLT, duplex printing, or staples [0~9999999/ 0 / 1]
	Total Counter	
8591 1	A3/DLT	
8591 2	Duplex Counter	
8591 3	Staples	Not used in this machine

8771	3-0-01	The number of rotations of the development rollers [0~9999999/ 0 / 1]
	Total Development Counter	
8771 1	Total	

8801	3-0-05	The percentage of the remaining toner [0~100/ 0 / 1]
	Toner Counter	
8801 1	Bk	

8941	3-6-01	The amount of time the machine spends in a specific mode [0~9999999/ 0 / 1]
	Checks the Machine Status	
8941 1	Operation time	
8941 2	Stand-by time	
8941 3	Energy Saver time	
8941 4	Sleep mode	
8941 5	Off mode time	
8941 6	Downtime/SC	
8941 7	Downtime/Printer Jam	
8941 8	Downtime/Scn Jam	
8941 9	Downtime/Toner End	

SP9-xxx: Counters

All level nine SP Modes are either DFU, or, not used in this machine.

5.4 UPDATING THE FIRMWARE

⚠ CAUTION
Do not turn off the machine while downloading the firmware.



5.4.1 TYPE OF FIRMWARE

The table lists the programs used by the machine. All programs can fit on one SD card.

	Type of firmware	Function	Location of firmware	Message shown
1	Engine - Main	Printer engine control	SD card	Engine
2	System	Printer system management	SD card	Onboard SYS
3	Printer Application	Feature application	SD card	Onboard Prt
4	Network support	Network application	SD card	Network support
5	Web support	Web service application	SD card	Web support

5.4.2 PRECAUTIONS

Handling SD Cards

Observe these precautions when you handle SD cards:

- Turn off the main power switch before you insert or remove an SD card. Data in the SD card can get corrupted if you insert or remove an SD card while the main power switch is on.
- Do not turn off the main power switch during downloading.
- Keep SD cards in a safe location. Do not store SD cards in these locations:
 - Locations that get high temperature, high humidity, direct sunlight, or strong vibration.
 - Locations where there are effects from magnetic forces
- Do not bend or scratch SD cards.
- Do not drop SD cards or expose them to shock or vibration.

Upload or Download

In this section “upload” and “download” have these meanings:

- Upload: To copy data from the printer to the SD card
- Download: To copy data from the SD card to the printer

Network Connection

Before you start, tell the user that they cannot use the printer during firmware update, and that they must disconnect the printer physically from the network. If a print job comes in, this can cause problems with the firmware update.



5.4.3 MACHINE FIRMWARE [G112/G113/G116]

NOTE: 1) Turn the machine off before you start the firmware update procedure.
2) This procedure will let you upgrade all programs for this machine.

1. Prepare a card that contains the required firmware.
2. Turn off the power and remove the cover [A] (1 screw).
3. Insert the card into the upper card slot [B] (slot 1).
4. Turn on the power.

NOTE: It takes about 30 seconds before you will see anything on the operation panel. "Onboard Sys" shows after 30 seconds.

5. Use the scroller to scroll to the program you want to upgrade (Example; Engine). Then press "enter"

6. Press the "online" button to start the upgrade procedure.

NOTE: It takes about 90 seconds to complete the upgrade procedure. Power on/off shows when the upgrade procedure has completed.

7. Turn off the power. Then remove the SD card from the slot.

8. Turn on the power.

NOTE: 1) Do the procedure again if you want to upgrade a different program.
2) The firmware is not upgraded successfully if "Turn power on/off" does not show on the operation panel after the sixth step. At this time, turn off the machine. Then do steps 1-6 again.

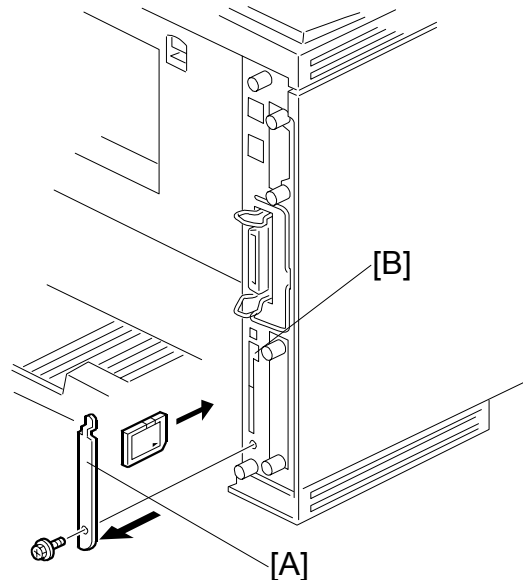

G116S510.WMF

Service
Tables

5.4.4 ERROR RECOVERY [G112/G113/G116]

Refer to the G091/G094/G095 Service Manual for details



5.5 NVRAM DATA UPLOAD/DOWNLOAD

⚠ CAUTION

Turn off the main power switch before you insert or remove an SD card.
Make sure that the controller and the EGB are correctly connected.

Uploading NVRAM Data

Copy the data from the NVRAM to an SD card (referred to as “to upload NVRAM data” in this section) before you replace the NVRAM. If you cannot upload NVRAM data, manually input the necessary settings after you replace the NVRAM

1. Start the SP mode.
2. Select SP 5990 1 (ALL).
3. Do the SP.
4. See if the SMC Report is correctly output.
NOTE: You may need the SMC Report when the machine did not complete an NVRAM data upload or download (☛ Downloading NVRAM Data) correctly.
5. Go out of the SP mode.
6. Turn off the main power switch.
7. Insert an SD card into the upper slot [A] (slot 1)
8. Turn on the main power switch.
9. Start the SP mode.
10. Select SP 5824 1 (NVRAM Upload).
11. Push the enter key. The upload starts.

NOTE: When uploading ends correctly, the following file is made:

- NVRAM\serial_number.NV where “NVRAM” is the folder name in the SD card and “serial_number.NV” is the file name with the extension “.NV”. The serial number of the printer is used as the file name. For example, if the serial number is G1160017, the file name is “G1160017.NV”.

12. Go out of the SP mode.
13. Turn off the main power switch.
14. Remove the SD card.
15. Mark the SD card with, for example, the machine code. You need this SD card when you download NVRAM data (☛ Downloading NVRAM Data).

NOTE: One SD card can store the NVRAM data from two or more machines.

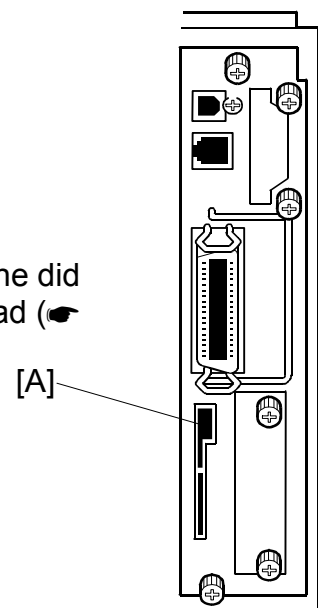

G116S511.WMF

Downloading NVRAM Data

Copy the data from the SD card to the NVRAM (referred to as “to download NVRAM data” in this section) after you replace the NVRAM. If you cannot download NVRAM data, manually input the necessary settings.

1. Make sure that the main power switch is off.
2. Make sure that you have the correct SD card that contains the necessary NVRAM data.
3. Insert the SD card into the upper slot [A] (slot 1).
4. Turn on the main power switch.
5. Start the SP mode.
6. Select SP 5825 1 (NVRAM Download).
7. Push the enter key. The download starts.

NOTE: The machine cannot do the download if the file name in the SD card is different from the serial number of the printer (☛Uploading NVRAM Data).

8. Go out of the SP mode.
9. Turn off the main power switch.
10. Remove the SD card.
11. Turn on the main power switch.
12. Check that the NVRAM data is correctly downloaded.

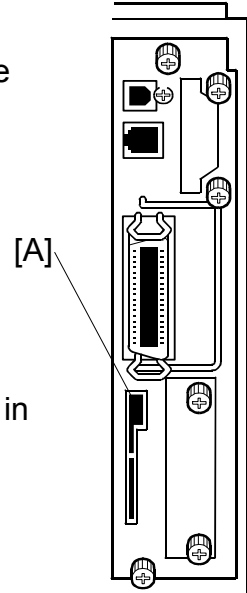

G116S511.WMF

5.6 REMOTE FIRMWARE UPDATE (RFU) [G112/G113/G116]

Refer to the G091/G094/G095 Service Manual for details

5.7 LOOP-BACK TEST [G112/G113/G116]

Refer to the G091/G094/G095 Service Manual for details

5.8 POWER-ON SELF TESTS [G112/G113/G116]

Refer to the G091/G094/G095 Service Manual for details

5.9 DIP SWITCHES [G112/G113/G116]

Refer to the G091/G094/G095 Service Manual for details



5.10 SD CARD APPLI MOVE

5.10.1 OVERVIEW

The service program “SD Card Appli Move” (SP 5873) lets you copy application programs from an SD card to another SD card.

Use extreme caution when do the SD Card Appli Move procedure:

1. The authentication data is transferred with the application program from an SD card to the other SD card. Authentication fails if you try to use the SD card after you copy the application program from this card to another SD card.
2. Do not use an SD card if it has been used for some other work, for example, on a computer. Normal operation is not guaranteed when such SD card is used.
3. Keep the SD card in the place (●Note) after you copy the application program from the card to another card. This is because: ① The SD card can be the only proof that the user is licensed to use the application program. ② You may need to check the SD card and its data to solve a problem in the future.

5.10.2 MOVE EXEC

The menu “Move Exec” (SP 5873 1) lets you copy application programs from the original SD card to another SD card. The application programs are copied from slot 1 [A] to slot 2 [B].

1. Turn off the main power switch.
2. Make sure that an SD card is in slot 1 [A]. The application program is copied to SD card in slot 1 [A].
3. Insert the SD card (having stored the application program) to slot 2 [B]. The application program is copied from this SD card.
4. Turn on the main power switch.
5. Start the SP mode.
6. Select SP 5873 1 “Move Exec.”
7. Follow the messages shown on the operation panel.
8. Go out of the SP mode.
9. Turn off the main power switch.
10. Remove the SD card from slot 2 [B].
11. Turn on the main power switch.
12. Check that the application programs run normally.

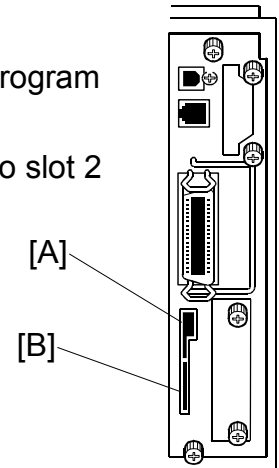

G116S511.WMF

5.10.3 UNDO EXEC

The menu “Undo Exec” (SP 5873 2) lets you copy back application programs from an SD card to the original SD card. You can use this program when, for example, you have mistakenly copied some programs by using Move Exec (SP 5873 1). The application programs are copied from slot 1 [A] to slot 2 [B].

1. Turn off the main power switch.
2. Insert the original SD card in slot 2 [B]. The application program is copied back to this card.
3. Make sure that the SD card (having stored the application program) is in slot 2 [B]. The application program is copied back from this SD card.
4. Turn on the main power switch.
5. Start the SP mode.
6. Select SP 5873 2 “Undo Exec.”
7. Follow the messages shown on the operation panel.
8. Go out of the SP mode.
9. Turn off the main power switch.
10. Remove the SD card from slot 2 [B]
11. Turn on the main power switch.
12. Check that the application programs run correctly.

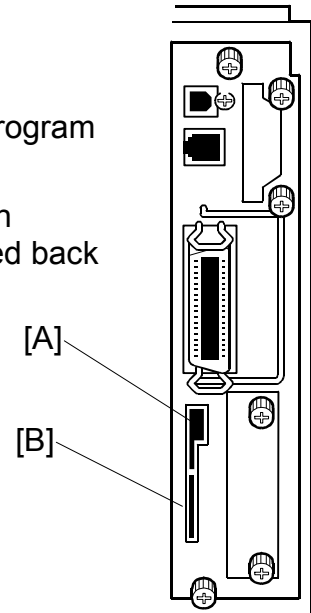

G116S511.WMF

6. DETAILED DESCRIPTIONS

6.1 OVERVIEW

The descriptions in this section are for the G112/G113/G116 machines. Details that are machine specific are shown with the machine codes.

6.1.1 MECHANICAL COMPONENT LAYOUT [G112/G113/G116]

Refer to the G091/G094/G095 Service Manual for details.

6.1.2 PAPER PATH [G112/G113]

Refer to the G091/G094/G095 Service Manual for details.

6.1.3 PAPER PATH [G116]

Refer to the G091/G094/G095 Service Manual for details.

6.2 BOARD STRUCTURE

6.2.1 BLOCK DIAGRAM [G112/G113]

Refer to the G091/G094/G095 Service Manual for details.

6.2.2 BLOCK DIAGRAM [G116]

Refer to the G091/G094/G095 Service Manual for details.

6.2.3 DESCRIPTIONS [G112/G113/G116]

Refer to the G091/G094/G095 Service Manual for details.

6.2.4 CONTROLLER [G112/G113]

Refer to the G091/G094/G095 Service Manual for details.

6.2.5 CONTROLLER [G116]

Refer to the G091/G094/G095 Service Manual for details.

6.3 PRINTING PROCESS

6.3.1 OVERVIEW [G112/G113/G116]

Refer to the G091/G094/G095 Service Manual for details.

6.3.2 LASER EXPOSURE [G112/G113/G116]

Refer to the G091/G094/G095 Service Manual for details.

Automatic Process Control (APC) [G112/G113/G116]

Refer to the G091/G094/G095 Service Manual for details.

LD Safety Mechanisms [G112/G113/G116]

Refer to the G091/G094/G095 Service Manual for details.

6.3.3 CARTRIDGE OVERVIEW [G112/G113/G116]

Refer to the G091/G094/G095 Service Manual for details.

6.3.4 DRUM CHARGE [G112/G113/G116]

Refer to the G091/G094/G095 Service Manual for details.

6.3.5 DEVELOPMENT [G112/G113/G116]

Refer to the G091/G094/G095 Service Manual for details.

Toner Density Control [G112/G113/G116]

Refer to the G091/G094/G095 Service Manual for details.

Toner End Detection [G112/G113/G116]

Refer to the G091/G094/G095 Service Manual for details.

6.3.6 IMAGE TRANSFER AND PAPER SEPARATION

Refer to the G091/G094/G095 Service Manual for details.

Overview [G112/G113/G116]

Refer to the G091/G094/G095 Service Manual for details.

Transfer Roller Cleaning [G112/G113/G116]

Refer to the G091/G094/G095 Service Manual for details.

6.3.7 CLEANING [G112/G113/G116]

Refer to the G091/G094/G095 Service Manual for details.

6.3.8 QUENCHING [G112/G113/G116]

Refer to the G091/G094/G095 Service Manual for details.

6.4 PAPER FEED

6.4.1 OVERVIEW [G112/G113/G116]

Refer to the G091/G094/G095 Service Manual for details.

6.4.2 PAPER TRAY [G112/G113/G116]

Refer to the G091/G094/G095 Service Manual for details.

Tray Extension [G112/G113/G116]

Refer to the G091/G094/G095 Service Manual for details.

Paper Lift [G112/G113/G116]

Refer to the G091/G094/G095 Service Manual for details.

Paper Feed and Registration [G112/G113/G116]

Refer to the G091/G094/G095 Service Manual for details.

Paper Size Detection [G112/G113/G116]

Refer to the G091/G094/G095 Service Manual for details.

Paper Size Detection [G112/G113]

Refer to the G091/G094/G095 Service Manual for details.

Paper Size Detection [G116]

Refer to the G091/G094/G095 Service Manual for details.

Paper End Detection [G112/G113/G116]

Refer to the G091/G094/G095 Service Manual for details.

Remaining Paper Detection [G112/G113/G116]

Refer to the G091/G094/G095 Service Manual for details.

6.4.3 BY-PASS TRAY [G112/G113/G116]

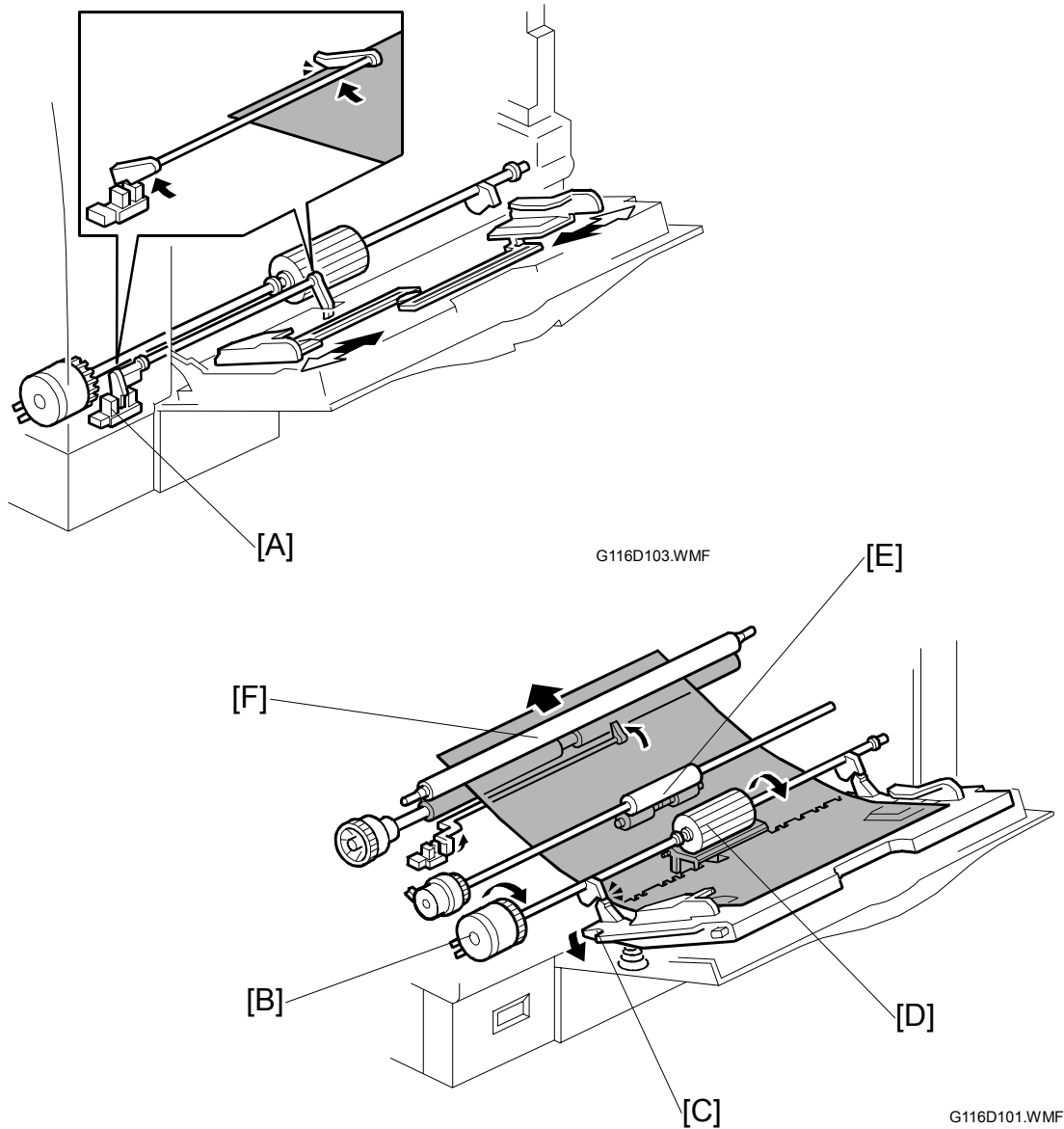

The bypass paper sensor [A] detects when paper is put on the tray. The CPU energizes the by-pass feed clutch [B]. Then the by-pass feed roller [D] starts to feed paper to the registration roller [F] through the relay roller [E].

The by-pass feed roller shaft has two cams [C]. These cams release the bottom plate to press the stack of paper against the feed roller.

NOTE: The feed roller has a metal plate to prevent bad effects from too much friction between the feed roller and friction pad.

6.5 IMAGE FUSING AND PAPER EXIT

6.5.1 OVERVIEW [G112/G113/G116]

Refer to the G091/G094/G095 Service Manual for details.

6.5.2 FUSING DRIVE [G112/G113/G116]

Refer to the G091/G094/G095 Service Manual for details.

6.5.3 FUSING ENTRANCE AND GUIDE SHAFT [G112/G113/G116]

Refer to the G091/G094/G095 Service Manual for details.

6.5.4 PRESSURE ROLLER [G112/G113/G116]

Refer to the G091/G094/G095 Service Manual for details.

6.5.5 NEW FUSING UNIT DETECTION [G112/G113/G116]

Refer to the G091/G094/G095 Service Manual for details.

6.5.6 FUSING TEMPERATURE CONTROL [G112/G113/G116]

Refer to the G091/G094/G095 Service Manual for details.

Overheat Protection [G112/G113/G116]

Refer to the G091/G094/G095 Service Manual for details.

6.5.7 PAPER EXIT [G112/G113/G116]

Refer to the G091/G094/G095 Service Manual for details.

6.5.8 ENERGY SAVER MODE [G112/G113/G116]

Refer to the G091/G094/G095 Service Manual for details.

6.6 CONTROLLER FUNCTIONS

6.6.1 METER CHARGE MODE [G112/G113/G116]

Refer to the G091/G094/G095 Service Manual for details.

SPECIFICATIONS (G112/G113)

1. GENERAL SPECIFICATIONS

The specifications in this section are for the G112/G113 machines only.

Configuration	Desktop	
Paper size	Legal SEF - A6SEF	
Technology	Laser beam scanning & Electro photographic printing Dual component toner development AIO is used	
Print Resolution	400 dpi, 600 dpi, 1200 dpi	
Smoothing	Yes (on, off)	
Continuous Print Speed	27 ppm (A4), 28 ppm (LT)	
Duplex Print Speed (A4)	27 ppm from standard tray	
	23 ppm from first optional paper tray	
	20 ppm from second optional paper tray	
First Print Speed	7.5 seconds or less (A4-SEF from standard tray)	
Copy Paper Weight	Paper Tray	60-105 g/m ² (16-28 lb.)
	By-pass tray	60-162 g/m ² (16-43 lb.)
	Optional paper tray	60-105 g/m ² (16-28 lb.)
	Duplex	64-105 g/m ² (17-28 lb.)
Warm-up Time	19 seconds or less from power on (23 °C, 73 °F)	
	12 seconds or less from energy saver mode	
Paper Input Size	Standard tray	LG – A5 LEF
	By-pass tray	LG – A6 SEF
	By-pass tray-Custom size paper	Length: 139.7 - 432 mm (5.5"- 17"), Width: 90 - 216 mm (3.5" - 8.5"), Com#10, C5, C6, DL. Monarch
	Optional Envelope Feeder	Com#10, C5, C6, DL. Monarch
	Optional paper tray unit Up to 2 units can be installed.	LG – A5 SEF
Paper Input Capacity	Standard tray and Optional paper trays	500 sheets (80 g/m ² , 20 lb.)
	By-pass tray	100 sheets (80 g/m ² , 20 lb.) or 10 envelopes
	Optional Envelope feeder	60 envelopes
Output Capacity	250 sheets	
Total Counter	Electric Counter	
Environmental Standard	US version: Energy Star Tier 1	
	EU version: BAM specifications	

2. PHYSICAL SPECIFICATIONS

Power Source	North America: 120 V, 60 Hz: More than 10 A		
	EU: 220 V - 240 V, 50/60 Hz: More than 6.0 A		
Power Consumption		120 V	230 V
	Maximum	790 W or less	790 W or less
	Printing	550 W or less	550 W or less
	Energy Saver	4 W or less	4 W or less
Noise Emission		Mainframe Only	Full System
	Printing	63 dB or less	67 dB or less
	Stand-by	39 dB or less	39 dB or less
	Energy Saver	39 dB or less	39 dB or less
Sound Pressure Level	Printing	53dB or less (operating position)	
	Stand-by	29dB or less (operating position)	
	Energy Saver	29dB or less (operating position)	
Weight	15.0 Kg (33 lb.)		
Dimensions	Excluding standard tray	388 x 410 x 345 (mm). 15.3 x 16.1 x 13.6 (inch)	
	Including standard try	388 x 450/509 x 345 (mm). 15.3 x 17.7/20.0 x 13.6 (inch)	

3. CONTROLLER

CPU	TMPR4955CFG 400 MHz	
Printer Languages	RPCS, PCL6, PCL5e emulation, Adobe PS3 (genuine), Adobe PDF	
Resolution	RPCS	600/1200 dpi
	PCL6	600/1200 dpi
	PCL5e	300/600 dpi
	PS3	600/1200 dpi
Resident Fonts	PCL	35 Intellifonts, 10 TrueType fonts, 1 bitmap font
	PS	136 Type1 fonts
	Font Manager and 31 additional fonts for PCL to be loaded to the PC, Euro currency ok.	
Drivers	RPCS	Win95/98/Me, Win NT 4.0, 2000, XP, Server 2003
	PCL6	Win95/98/Me, Win NT 4.0, 2000, XP, Server 2003
	PCL5e	Win95/98/Me, Win NT 4.0, 2000, XP, Server 2003
	PS3	Win95/98/Me, Win NT 4.0, 2000, XP, Server 2003
	Mac OS 8.6.0 or later, Mac OSX (10.1 or later)	
ROM	Flash: 24 MB (Emulation) Mask: 8MB (PCL/PS font)	
RAM	Standard	G112: 64 MB SDRAM
		G113: 128 MB SDRAM
	Optional	G112: 64/128/256 MB (Maximum 320 MB)
		G113: 256 MB (Maximum 256 MB)
HDD	Option: Approximately 6 GB	
Interface	Standard	USB2.0 (Win98, 2000, ME, XP, Server 2003) Bi-directional IEEE1284 10/100 Base-TX (G113)
	Optional	<ul style="list-style-type: none"> • IEEE1394, SCSI Print (Windows 2000 SP1 or later). • IP over 1394 Windows Me, XP, Server 2003 • IEEE802.11b, 10/100 Base-TX (G112), Bluetooth
Firmware Update	SD card (1 card)	
	RFU (Remote Firmware Update)	
Network Protocol	TCP/IP (including IPP), IPX/SPX, NetBEUI, Apple Talk	
NRS	Supported	

- NOTE:** 1) One optional interface board can be added
2) 10/100Base-TX and IEEE802.11b cannot be connected at the same time. Manual switch at the operation panel is required (user tool)

4. SUPPORTED PAPER SIZES

Paper Name	Direction (Edge)	Paper Size width x length	Main Unit / Bank		Bypass Tray		Env. Feeder	Duplex
			NA	EU	NA	EU	NA/EU	NA/EU
A4	Short Edge	210 x 297 mm	D/D	D/D	S	S	N	Y
B5	Short Edge	182 x 257 mm	D/D	D/D	S	S	N	Y
A5	Short Edge	148 x 210 mm	D/D	D/D	S	S	N	Y
A5	Long Edge	210 x 148 mm	*/N	*/N	S	S	N	Y
B6	Short Edge	128 x 182 mm	N/N	N/N	N	N	N	N
B6	Long Edge	182 x 128 mm	N/N	N/N	N	N	N	N
A6	Short Edge	105 x 148 mm	N/N	N/N	S	S	N	N
A6	Long Edge	148 x 105 mm	N/N	N/N	N	N	N	N
Legal	Short Edge	8.5 x 14 inch	D/D	D/D	S	S	N	Y
Letter	Short Edge	8.5 x 11 inch	D/D	D/D	S	S	N	Y
Half Letter	Short Edge	5.5 x 8.5 inch	D/D	D/D	S	S	N	Y
Half Letter	Long Edge	8.5 x 5.5 inch	*/N	*/N	S	S	N	Y
Executive	Short Edge	7.25 x 10.5 inch	N/*	N/*	S	S	N	N
F	Short Edge	8 x 13 inch	*/*	*/*	S	S	N	Y
Foolscap	Short Edge	8.5 x 13 inch	*/*	*/*	S	S	N	Y
Folio	Short Edge	8.25 x 13 inch	*/*	*/*	S	S	N	Y
Com10	Short Edge	4.125 x 9.5 inch	N/N	N/N	S	S	S	N
Monarch	Short Edge	3.875 x 7.5 inch	N/N	N/N	S	S	S	N
C6	Short Edge	114 x 162 mm	N/N	N/N	S	S	S	N
C5	Short Edge	162 x 229 mm	N/N	N/N	S	S	S	N
DL Env	Short Edge	110 x 220 mm	N/N	N/N	S	S	S	N
16k	Short Edge	195 x 267 mm	*/*	*/*	S	S	N	Y
Custom	Width (Bank)	139.7-216.0 mm	*/-	*/-	-	-	N	N
	Length (Bank)	160.0 -356.0 mm	*/-	*/-	-	-	N	N
	Width (Bypass)	90.0-216.0 mm	-	-	S	S	N	N
	Length (Bypass)	139.7-432.0 mm	-	-	S	S	N	N

D: Paper size is specified by using the dial.

* : Supported. The user has to select the correct paper size for the tray from the user menu.

S: Paper size is entered at the operation panel.

N: Not supported

Y: Supported

5. OPERATION PANEL LED SPECIFICATIONS

LED	Color	Appearance	Meaning
Power	Green	Off	Power off or in Energy Saver mode
		Flashing	Warming up
		On	Power on and not in Energy Saver mode
Data In	Green	Off	No data
		Flashing	Data being received or processed or the printer is spooling
		On	Data being received or processed; more data coming
Online	Green	Off	Printer off-line
		Flashing	Going off-line
		On	Ready to print
Error	Red	Off	No messages or error conditions requiring attention
		On	Printer requires service

6. EXTERNAL OPTIONS

Paper Feed Unit (Type 400) (G360)	Paper Size	A4 SEF – A5 SEF, LG SEF-A5 SEF, Free size
	Paper Weight	60 – 105g/m ² , 16 – 28 lb.
	Paper Capacity	Maximum 500 sheets
	Dimensions (W x D x H)	388 x 427/486 x 135 mm 15.3" x 16.8/19.1" x 5.3"
	Weight	Less than 6 Kg, 13.2 lb.
Envelope Feeder (Type 400) (G362)	Envelope size	Com#10, C5, C6, DL, Monarch
	Capacity	Maximum 60
	Dimensions (W x D x H)	359 x 427 x 101 mm 14.1" x 16.8" x 4.0"
	Weight	Less than 6 Kg, 13.2 lb.
Duplex Unit (AD 450) (G361)	Paper Size	A4 SEF – A5 LEF
	Paper Weight	60 – 105g/m ² , 16 – 28 lb.
	Dimensions (W x D x H)	340 x 380 x 250 mm 13.4" x 15.0" x 9.8"
	Weight	Less than 6 Kg, 13.2 lb.

7. SOFTWARE ACCESSORIES

The printer drivers and utility software are provided on one CD-ROM. An auto-run installer allows you to select which components to install.

7.1 PRINTER DRIVERS

Printer Language	Windows 95/98/ME	Windows NT4.0	Windows 2000	Windows XP	Server 2003	Macintosh
PCL 6	Yes	Yes	Yes	Yes	Yes	No
PCL 5e	Yes	Yes	Yes	Yes	Yes	No
PS3	Yes	Yes	Yes	Yes	Yes	Yes
RPCS	Yes	Yes	Yes	Yes	Yes	No

- NOTE:** 1) The printer drivers for Windows NT 4.0 are only for the Intel x86 platform. There is no Windows NT 4.0 printer driver for the PowerPC, Alpha, or MIPS platforms.
- 2) The PS3 drivers are all genuine AdobePS drivers, except for Windows 2000, which uses Microsoft PS. A PPD file for each operating system is provided with the driver.
- 3) The PS3 driver for Macintosh supports Mac OS 7.6 or later versions.

7.2 CD-ROM CONTENTS

7.2.1 NORTH AMERICAN VERSION

Utilities and Drivers CD-ROM

Environment	Contents	Language	Remarks
Windows	RPCS Driver	14 languages	Windows 95/98/Me, NT4.0, 2000, XP, Server 2003
	PCL6 Driver	14 languages	Windows 95/98/Me, NT4.0, 2000, XP, Server 2003
	PCL5e Driver	14 languages	Windows 95/98/Me, NT4.0, 2000, XP, Server 2003
	Adobe PS3 Printer Driver	9 languages	Windows 95/98/Me, NT4.0, 2000, XP, Server 2003
	Font Manager	English only	Windows 95/98/Me, NT4.0, 2000, XP, Server 2003
	SmartNetMonitor (Client)	14 languages	Windows 95/98/Me, NT4.0, 2000, XP, Server 2003
	SmartNetMonitor (Admin)	14 languages	Windows 95/98/Me, NT4.0, 2000, XP, Server 2003
	1394 UTILITY	English only	Windows 2000, XP
	README.TXT	English only	–
Macintosh	Adobe PS3 Printer Driver	9 languages	English, German, Spanish, French, Italian, Dutch, Swedish, Norwegian, Danish
	PS Descriptions	9 languages	English, German, Spanish, French, Italian, Dutch, Swedish, Norwegian, Danish
	Printer Utility for Mac	English only	–

Operating Instructions CD-ROM

Environment	Contents	Language	Remarks
Windows Macintosh	Setup Guide	English only	–
	Printer Reference	English only	–
	NIB Operating Instructions	English only	–
	PS Supplement	English only	–
	Adobe Acrobat Reader	English only	–

7.2.2 EUROPEAN VERSION**Utilities and Drivers CD-ROM**

Environment	Contents	Language	Remarks
Windows	RPCS Driver	14 languages	Windows 95/98/Me, NT4.0, 2000, XP, Server 2003
	PCL6 Driver	14 languages	Windows 95/98/Me, NT4.0, 2000, XP, Server 2003
	PCL5e Driver	14 languages	Windows 95/98/Me, NT4.0, 2000, XP, Server 2003
	Adobe PS3 Printer Driver	9 languages	Windows 95/98/Me, NT4.0, 2000, XP, Server 2003
	Font Manager	English only	Windows 95/98/Me, NT4.0, 2000, XP, Server 2003
	SmartNetMonitor (Client)	14 languages	Windows 95/98/Me, NT4.0, 2000, XP, Server 2003
	SmartNetMonitor (Admin)	14 languages	Windows 95/98/Me, NT4.0, 2000, XP, Server 2003
	1394 UTILITY	English only	Windows 2000, XP
	README.TXT	English only	–
Macintosh	Adobe PS3 Printer Driver	9 languages	English, German, Spanish, French, Italian, Dutch, Swedish, Norwegian, Danish
	PS Descriptions	9 languages	English, German, Spanish, French, Italian, Dutch, Swedish, Norwegian, Danish
	Printer Utility for Mac	English only	–

Operating Instructions CD-ROM

Environment	Contents	Language	Remarks
Windows Macintosh	Setup Guide	14 languages	Prepared by RE as paper manual
	Printer Reference	14 languages	–
	NIC Operating Instructions	14 languages	–
	PS Supplement	9 languages	English, German, Spanish, French, Italian, Dutch, Swedish, Norway, Denmark
	Adobe Acrobat Reader	8 languages	English, German, Spanish, French, Italian, Dutch, Portuguese, Swedish

8. MACHINE CONFIGURATION

8.1 SYSTEM COMPONENTS

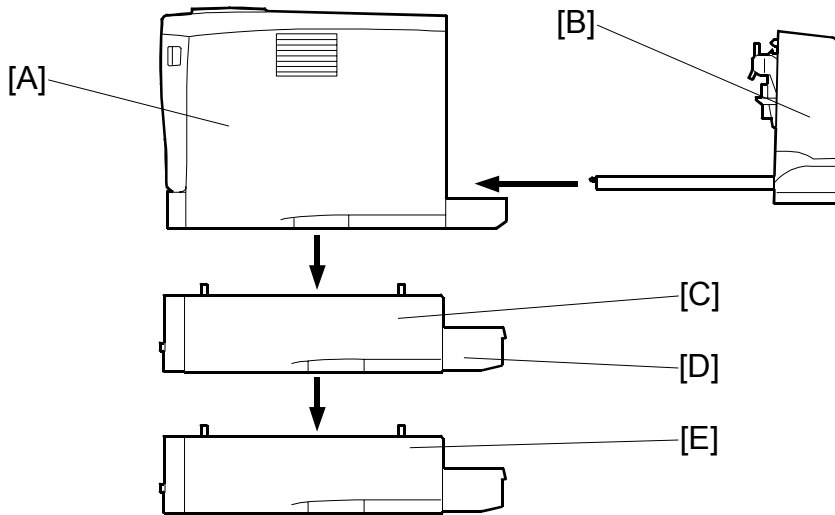

G112V205.WMF

Item	Machine Code	No.	Remarks
Main Unit	G112 G113	A	The NIB option is built into the G113 model but not for the G112 model.
Optional Units			
Duplex Unit	G361	B	
Paper Tray Unit	G360	C, D	Up to two tray units can be installed.
Envelope Feeder	G362	E	If both optional paper trays are installed, the envelope feeder must go in the top tray.

NOTE: The user can install all of the above items.

8.2 INTERNAL OPTIONS

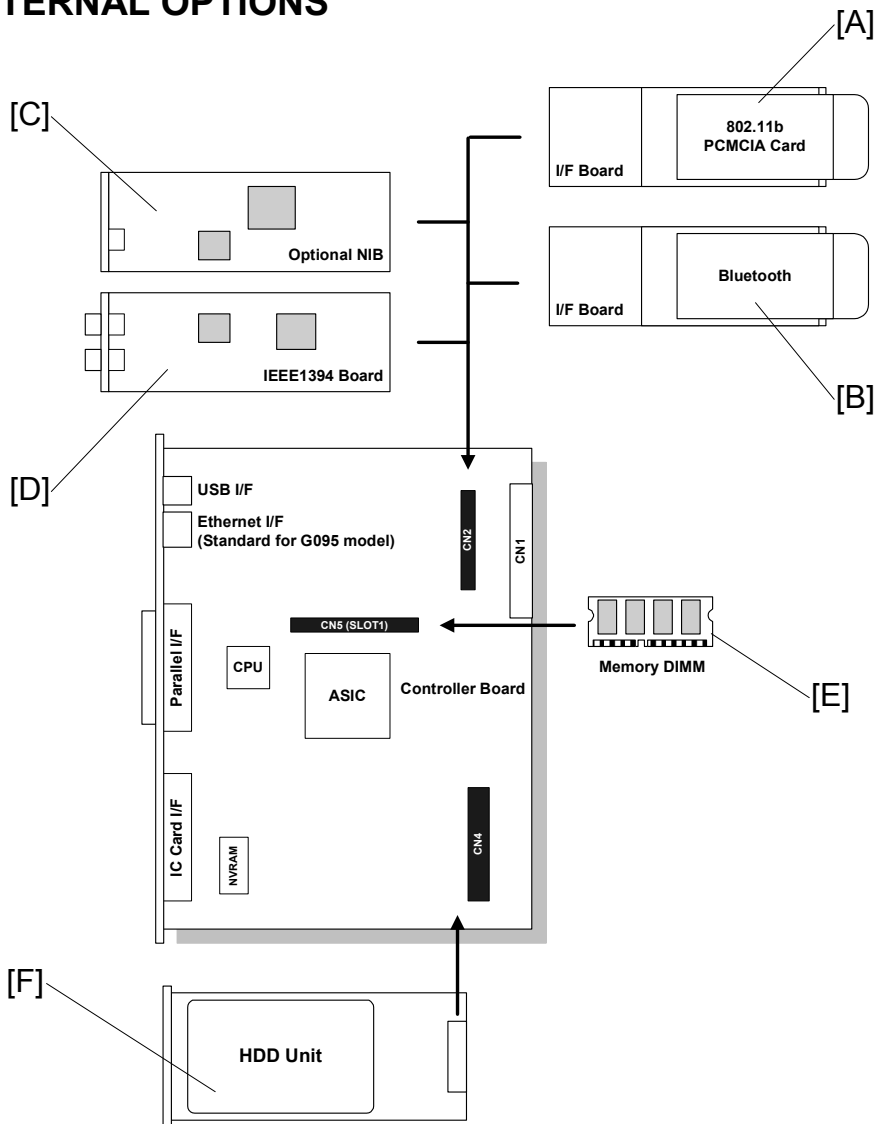

G112V206.WMF

Item	Machine Code	No.	Remarks
Internal Options			
NIB (10/100Base-TX) (Standard for G113)	G646	C	Also used with model C-P1
IEEE1394 I/F Board	G336	D	Also used with model C-P1
IEEE802.11b	G813	A	
Bluetooth Type C	G354	B	
HDD	G575	F	Also used with model C-P1
DESS	G820		
Memory 64 MB	G330	E	Also used with model C-P1, G112 only
Memory 128 MB	G331	E	Also used with model C-P1, G112 only
Memory 256 MB	G332	E	Also used with model C-P1
Barcode Font DIMM	G627		Also used with model C-P1
Others			
AIO Cartridge	G216		Also used with model C-P1
Maintenance Kit	G263		

SPECIFICATIONS (G116)

1. GENERAL SPECIFICATIONS

The specifications in this section are for the G116 machine only.

Configuration	Desktop	
Paper size	Legal SEF – A6 SEF. A5 LEF not supported	
Technology	Laser beam scanning & Electro photographic printing Dual component toner development AIO is used	
Print Resolution	200/300/600/1200 dpi	
Smoothing	Yes (on, off)	
Continuous Print Speed	LEF A4 Mono 35 ppm	
	LT Mono 35 ppm	
Duplex Print Speed (A4-LEF)	34 ppm from standard tray	
	34 ppm from first optional paper tray	
	33 ppm from second optional paper tray	
First Print Speed	6.5 seconds or less (A4/LT, LEF from standard tray)	
Copy Paper Weight	Paper Tray	60-105 g/m ² (16-28 lb.)
	By-pass tray	52-162 g/m ² (14-43 lb.)
	Optional paper tray	60-105 g/m ² (16-28 lb.)
	Duplex	64-105 g/m ² (17-28 lb.)
Warm-up Time	19 seconds or less from power on (23 °C, 73 °F)	
	12 seconds or less from energy saver mode	
Paper Input Size	Standard tray	A3/DLT – A5
	By-pass tray	A3/DLT – A6, Free size
	By-pass tray-Custom size paper	Length: 160 - 432 mm (5.8" - 17"), Width: 90 - 305 mm (3.5" - 12"), Com#10, C5, C6, DL. Monarch
	Optional Envelope Feeder	Com#10, C5, C6, DL. Monarch
	Optional paper tray unit Up to 2 units can be installed.	A3/DLT – A5
Paper Input Capacity	Standard tray and Optional paper trays	500 sheets (80 g/m ² , 20 lb.)
	By-pass tray	100 sheets (80 g/m ² , 20 lb.)
	Optional Envelope feeder	60 envelopes
	Maximum paper input	1600 sheets
Output Capacity (Face down)	250 sheets (Maximum 500 sheets)	
Total Counter	Electric Counter	
Environmental Standard	US version: Energy Star Tier 1	
	EU version: BAM specifications	
Energy Saver Mode	Default 15 minutes	
	Selectable 1/5/15/30/45/60 minutes	

2. PHYSICAL SPECIFICATIONS

Power Source	North America: 120 V, 60 Hz: More than 10 A		
	Europe: 220 V- 240 V, 50/60 Hz: More than 6.0 A		
Power Consumption North America	North America	Main Unit (including NIB)	Full system
	Maximum	850 W or less	920 W or less
	Printing	610 W or less	650 W or less
	Energy Saver	5.5 W or less	9.0 W or less
Power Consumption Europe	Europe	Main Unit (including NIB)	Full system
	Maximum	850 W or less	920 W or less
	Printing	620 W or less	650 W or less
	Energy Saver	6.5 W or less	10.5 W or less
Noise Emission All Models		Mainframe Only	Full System
	Printing	67 dB or less	71 dB or less
	Stand-by	40 dB or less	40 dB or less
	Energy Saver	40 dB or less	40 dB or less
Sound Pressure Level All Models	Printing	55dB or less (Operating position)	
	Energy Saver	30dB or less (Operating position)	
Weight All Models	20 Kg. 44 lb. (including Paper Tray and AIO)		
Dimensions All Models	Excluding standard tray	478 x 410 x 343 (mm). 18.8 x 16.1 x 13.5 (inch)	
	Including standard tray	478 x 437/575 x 343 (mm). 18.8 x 17.2 /22.6x 13.5 (inch)	

3. CONTROLLER

CPU	TX4955 372Mhz	
Printer Languages	Standard	RPCS, PCL6, PCL5e emulation, Adobe PS3 (genuine), Adobe PDF
Resolution	RPCS	600/1200 dpi
	PCL6	600/1200 dpi
	PCL5e	300/600 dpi
	PS3	600/1200 dpi
Resident Fonts	PCL	35 Intellifonts, 10 TrueType fonts, 1 bitmap font
	PS	136 Type1 fonts
	Font Manager and 31 additional fonts for PCL to be loaded to the PC, Euro currency ok.	
	Optional	OCR, Barcode
Drivers	RPCS	Win95/98/Me, Win NT 4.0, 2000, XP, Server 2003
	PCL6	Win95/98/Me, Win NT 4.0, 2000, XP, Server 2003
	PCL5e	Win95/98/Me, Win NT 4.0, 2000, XP, Server 2003
	PS3	Win95/98/Me, Win NT 4.0, 2000, XP, Server 2003
	Mac OS 8.6.0 or later, Mac OSX (10.1 or later)	
ROM	Flash: 16 MB (Emulation) Mask: 4MB (PCL/PS font)	
RAM	Standard	128 MB SODIMM
	Maximum	256 MB (Maximum 256 MB)
HDD	Option: 6 GB	
Interface	Standard	<ul style="list-style-type: none"> • USB2.0 (Win98, 2000, ME, XP, Server 2003) • NIC • Bi-directional IEEE1284 • 10/100 Base-TX
	Optional	<ul style="list-style-type: none"> • IEEE1394, SCSI Print (Windows 2000 SP1 or later). • IP over 1394 Windows Me, XP, Server 2003 • IEEE802.11b, Bluetooth
Firmware Update	SD card. One SD card holds all programs	
	RFU (Remote Firmware Update)	
Network Protocol	TCP/IP (including IPP), IPX/SPX, SMBI, Apple Talk	
NRS	Supported	
DESS	Supported	

- NOTE:**
- 1) One optional interface board can be added
 - 2) 10/100Base-TX and IEEE802.11b cannot be connected at the same time. Manual switch at the operation panel is required (user tool)
 - 3) The machine has a maximum memory capacity of 256 MB. You must replace the 128 MB memory board with the 256 MB memory board if you want to increase the machine memory.

4. SUPPORTED PAPER SIZES

Paper	Size (W x L)	Paper Trays Main Unit/Option		By-pass Tray	Env. Feeder	Duplex
		US	Eur/Asia			
A3	297 x 420 mm	Y [#] /Y	Y/Y	Y [#]	N	Y
B4	257 x 364 mm	Y [#] /Y [#]	Y [#] /Y [#]	Y [#]	N	Y
A4 SEF	210 x 297 mm	Y [#] /Y	Y/Y	Y [#]	N	Y
A4 LEF	297 x 210 mm	Y/Y	Y/Y	Y [#]	Y	Y
B5 SEF	182 x 257 mm	Y [#] /Y [#]	Y [#] /Y [#]	Y [#]	N	Y
B5 LEF	257 x 182 mm	Y [#] /Y [#]	Y [#] /Y [#]	Y [#]	N	Y
A5 SEF	148 x 210 mm	N	N	Y [#]	N	N
A5 LEF	210 x 148 mm	Y [#] /N	Y/N	Y [#]	N	Y
A6 SEF	105 x 148 mm	N	N	Y ^C	N	N
Ledger	11 x 17"	Y/Y	Y [#] /Y	Y [#]	N	Y
Legal	8.5 x 14"	Y/Y	Y [#] /Y	Y [#]	N	Y
Letter SEF	8.5 x 11"	Y/Y	Y/Y	Y [#]	N	Y
Letter LEF	11 x 8.5"	Y/Y	Y/Y	Y [#]	N	Y
Half Letter SEF	5.5 x 8.5"	N	N	Y [#]	N	N
Half Letter LEF	8.5 x 5.5"	N	N	N	N	N
Executive SEF	7.25 x 10.5"	N/Y [#]	N/Y [#]	Y [#]	N	N
Executive LEF	10.5 x 7.25"	Y [#] /Y [#]	Y [#] /Y [#]	Y [#]	N	Y
F	8 x 13"	Y [#] /Y [#]	Y [#] /Y [#]	Y [#]	N	Y
Foolscap	8.5 x 13"	Y/Y [#]	Y [#] /Y [#]	Y [#]	N	Y
Folio	8.25 x 13"	Y [#] /Y [#]	Y [#] /Y [#]	Y [#]	N	Y
Com10 Env.	4.125 x 9.5"	N	N	Y [#]	Y [#]	N
Monarch Env.	3.875 x 7.5"	N	N	Y [#]	Y [#]	N
C6 Env.	114 x 162 mm	N	N	Y [#]	Y [#]	N
C5 Env.	162 x 229 mm	N	N	Y [#]	Y [#]	N
DL Env.	110 x 220 mm	N	N	Y [#]	Y [#]	N
8K	267 x 390 mm	Y [#] /Y [#]	Y [#] /Y [#]	Y [#]	N	Y
16K SEF	195 x 267 mm	Y [#] /Y [#]	Y [#] /Y [#]	Y [#]	N	Y
16K LEF	267 x 195 mm	Y [#] /Y [#]	Y [#] /Y [#]	Y [#]	N	Y
Custom	Minimum: 90 x 148 mm Maximum: 305 x 432 mm	N/Y ^C	N/Y ^C	Y ^C	N	N

Y : Supported. The paper size sensor detects the paper size.

Y[#] : Supported. The user has to select the correct paper size for the tray.

Y^C : Supported. The user has to enter the width and length of the paper.

N : Not supported.

5. OPERATION PANEL LED SPECIFICATIONS

LED	Color	Appearance	Meaning
Power	Green	Off	Power off or in Energy Saver mode
		Flashing	Warming up
		On	Power on and not in Energy Saver mode
Data In	Green	Off	No data
		Flashing	Data being received or processed or the printer is spooling
		On	Data being received or processed; more data coming
Online	Green	Off	Printer off-line
		Flashing	Going off-line
		On	Ready to print
Error	Red	Off	No messages or error conditions requiring attention
		On	Printer requires service

6. EXTERNAL OPTIONS

Paper Feed Unit (G399)	Paper Size	A3/ 11" x 17"-B5 LEF
	Paper Weight	60 – 105g/m ² , 16 – 28 lb.
	Paper Capacity	Maximum 500 sheets
	Dimensions (W x D x H)	468 x 410/545 x 130 mm 18.4" x 19.7"/21.5" x 5.1"
	Weight	6 kg, 13.2 lb.
Envelope Feeder (G807)	Envelope size	Com#10, C5, C6, DL, Monarch
	Capacity	Maximum 60
	Dimensions (W x D x H)	468 x 410 x 127 mm 18.4" x 16.1" x 5"
	Weight	2 kg, 4.4 lb
Duplex Unit (G806)	Paper Size	A3/ 11" x 17"-A5 LEF
	Paper Weight	64 – 105g/m ² , 18 – 28 lb.
	Dimensions (W x D x H)	419 x 378 x 257 mm 16.5" x 14.9" x 10.1"
	Weight	6 kg, 13.2 lb.

7. SOFTWARE ACCESSORIES

The printer drivers and utility software are provided on one CD-ROM. An auto-run installer allows you to select which components to install.

7.1 PRINTER DRIVERS

Printer Language	Windows 95/98/ME	Windows NT4.0	Windows 2000	Windows XP	Server 2003	Macintosh
PCL 6	Yes	Yes	Yes	Yes	Yes	No
PCL 5e	Yes	Yes	Yes	Yes	Yes	No
PS3	Yes	Yes	Yes	Yes	Yes	Yes
RPCS	Yes	Yes	Yes	Yes	Yes	No

- NOTE:**
- 1) The printer drivers for Windows NT 4.0 are only for the Intel x86 platform. There is no Windows NT 4.0 printer driver for the PowerPC, Alpha, or MIPS platforms.
 - 2) The PS3 drivers are all genuine AdobePS drivers, except for Windows 2000, which uses Microsoft PS. A PPD file for each operating system is provided with the driver.
 - 3) The PS3 driver for Macintosh supports Mac OS 7.6 or later versions.

7.2 OPERATING SYSTEMS/NETWORKS

Operating Systems/Network	Windows 95/98/NT4.0/2000/Me/XP/Server 2003
	Netware 3.12, 3.2, 4.1, 4.11, 5.0, 5.1, 6
	Unix (using Ricoh UNIX filter)
	Mac OS 8.6-9.2x, OS X 10.1 or later

7.3 CD-ROM CONTENTS

7.3.1 NORTH AMERICAN VERSION

Utilities and Drivers CD-ROM

Environment	Contents	Language	Remarks
Windows	RPCS Driver	14 languages	Windows 95/98/Me, NT4.0, 2000, XP, Server 2003
	PCL6 Driver	14 languages	Windows 95/98/Me, NT4.0, 2000, XP, Server 2003
	PCL5e Driver	14 languages	Windows 95/98/Me, NT4.0, 2000, XP, Server 2003
	Adobe PS3 Printer Driver	9 languages	Windows 95/98/Me, NT4.0, 2000, XP, Server 2003
	Font Manager	English only	Windows 95/98/Me, NT4.0, 2000, XP, Server 2003
	SmartNetMonitor (Client)	14 languages	Windows 95/98/Me, NT4.0, 2000, XP, Server 2003
	SmartNetMonitor (Admin)	14 languages	Windows 95/98/Me, NT4.0, 2000, XP, Server 2003
	1394 UTILITY	English only	Windows 2000, XP
	README.TXT	English only	–
Macintosh	Adobe PS3 Printer Driver	9 languages	English, German, Spanish, French, Italian, Dutch, Swedish, Norwegian, Danish
	PS Descriptions	9 languages	English, German, Spanish, French, Italian, Dutch, Swedish, Norwegian, Danish
	Printer Utility for Mac	English only	–

Operating Instructions CD-ROM

Environment	Contents	Language	Remarks
Windows Macintosh	Setup Guide	English only	–
	Printer Reference	English only	–
	NIB Operating Instructions	English only	–
	PS Supplement	English only	–
	Adobe Acrobat Reader	English only	–

7.3.2 EUROPEAN VERSION

Utilities and Drivers CD-ROM

Environment	Contents	Language	Remarks
Windows	RPCS Driver	14 languages	Windows 95/98/Me, NT4.0, 2000, XP, Server 2003
	PCL6 Driver	14 languages	Windows 95/98/Me, NT4.0, 2000, XP, Server 2003
	PCL5e Driver	14 languages	Windows 95/98/Me, NT4.0, 2000, XP, Server 2003
	Adobe PS3 Printer Driver	9 languages	Windows 95/98/Me, NT4.0, 2000, XP, Server 2003
	Font Manager	English only	Windows 95/98/Me, NT4.0, 2000, XP, Server 2003
	SmartNetMonitor (Client)	14 languages	Windows 95/98/Me, NT4.0, 2000, XP, Server 2003
	SmartNetMonitor (Admin)	14 languages	Windows 95/98/Me, NT4.0, 2000, XP, Server 2003
	1394 UTILITY	English only	Windows 2000, XP
	README.TXT	English only	–
Macintosh	Adobe PS3 Printer Driver	9 languages	English, German, Spanish, French, Italian, Dutch, Swedish, Norwegian, Danish
	PS Descriptions	9 languages	English, German, Spanish, French, Italian, Dutch, Swedish, Norwegian, Danish
	Printer Utility for Mac	English only	–

Operating Instructions CD-ROM

Environment	Contents	Language	Remarks
Windows Macintosh	Setup Guide	14 languages	Prepared by RE as paper manual
	Printer Reference	14 languages	–
	NIC Operating Instructions	14 languages	–
	PS Supplement	9 languages	English, German, Spanish, French, Italian, Dutch, Swedish, Norway, Denmark
	Adobe Acrobat Reader	8 languages	English, German, Spanish, French, Italian, Dutch, Portuguese, Swedish

8. MACHINE CONFIGURATION

8.1 SYSTEM COMPONENTS

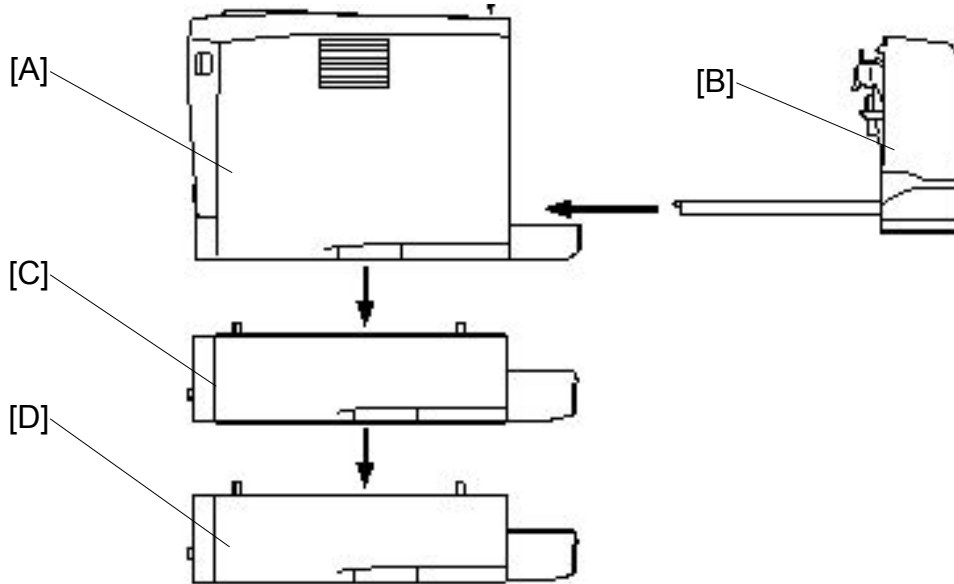

G116V107.JPG

Item	Machine Code	No.	Remarks
Main Unit	G116	A	The NIB is standard for this model.
Optional Units			
Duplex Unit	G806	B	
Paper Tray Unit	G399	C, D	Up to two tray units can be installed.
Envelope Feeder	G807	C	If both optional paper trays are installed, the envelope feeder must go in the top tray.

8.2 INTERNAL OPTIONS

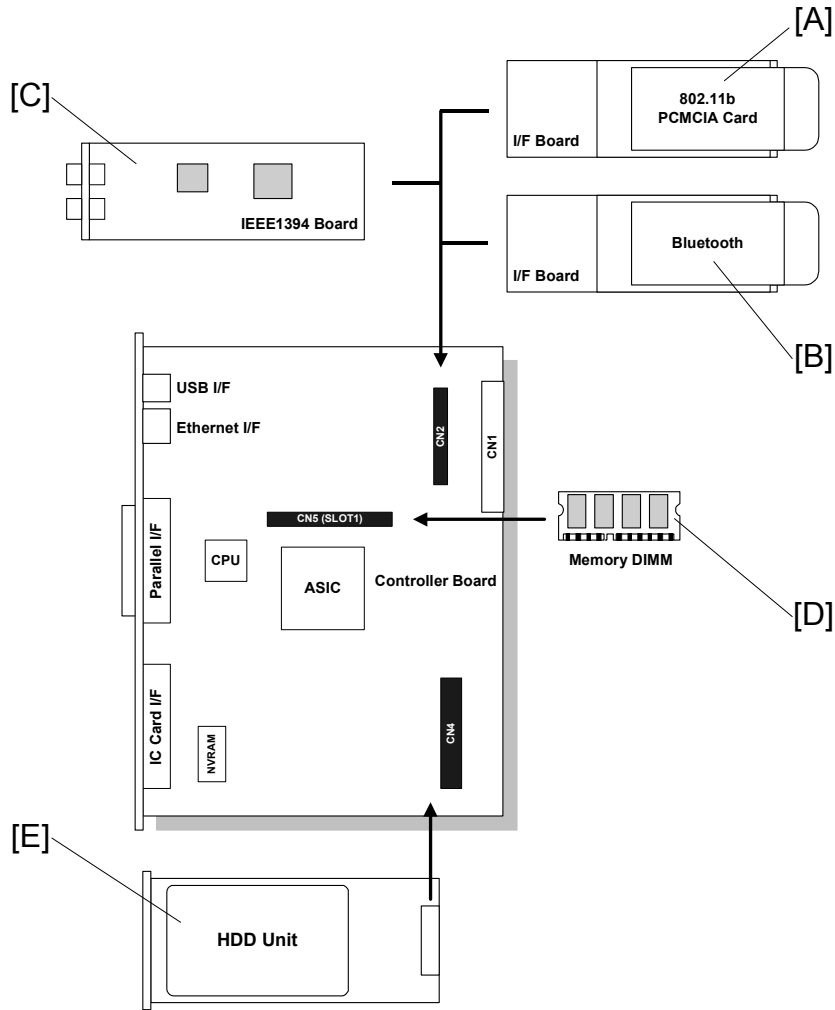

G116V900A.WMF

Item	Machine Code	No.	Remarks
Internal Options			
IEEE1394 I/F Board	G336	C	Also used with model K-P3
IEEE802.11b	G813	A	
Bluetooth Type C	G354	B	
DESS	G820		
HDD	G575	E	Also used with model K-P3
Memory 256 MB	G332	D	Also used with model K-P3
Barcode Font DIMM	G627		Also used with model K-P3
Others			
AIO Cartridge	G795		Also used with model K-P3
Maintenance Kit	G263		

NOTE: This model has an on-board Ethernet interface.

Spec.